



Product Catalog

Variable Refrigerant Flow (VRF) System Air Source Heat Pump and Heat Recovery Outdoor Units

4TVH/4TVR0072-0192 Single Unit Modules
4TVH/4TVR0216-0528 Multi-Unit Modules





Introduction

Trane® variable refrigerant flow (VRF) systems are efficient, effective, reliable heating and cooling solutions that you can trust. VRF is well suited for historic buildings without existing ductwork, as well as schools and mid-rise office buildings with multiple interior spaces and diverse occupancy rates. When VRF is the right solution for your application, Trane will help you ensure that it is the best solution.

Trane VRF systems are designed for exceptional energy efficiency, offering industry-leading performance up to 38.20 IEER and 34.10 SCHE. Trane VRF systems utilize inverter compressors (some model feature dual compressors) with vapor injection for improved performance and comfort.

Systems are available for both heat pump and simultaneous heating and cooling operation. Both feature individual zone control to provide individual occupant comfort. The simultaneous heating and cooling models offer the ability to heat and cool adjacent zones, intelligently exchanging energy between them through strategically located mode control units.

Indoor units are available in a wide variety of configurations and capacities, allowing architects the flexibility to satisfy almost any design requirement.

Trane offers a complete line-up of controls to complete your VRF installation. These range from easy to use individual zone controls to centralized systems for building monitoring and control, as well as optional BACnet® connectivity for centralized Trane Tracer™ integration.

Copyright

This document and the information in it are the property of Trane, and may not be used or reproduced in whole or in part without written permission. Trane reserves the right to revise this publication at any time, and to make changes to its content without obligation to notify any person of such revision or change.

Trademarks

All trademarks referenced in this document are the trademarks of their respective owners.

Revision History

Revisions include the following:

- Added 14 and 16 ton single modules.
- Updated system combinations to include new 14 and 16 ton modules (where applicable).
- Increased maximum system capacity to 44 tons.



Table of Contents

System Features	4
Model Number Description	5
System Combination Line-Up.....	6
Products	8
Application Matrix	8
Controls.....	9
Accessories	10
Product Specifications	12
Outdoor Unit Operation Limits.....	82
Defrosting Correction Factor	83
Electrical Wiring Diagrams — Outdoor Units.....	84
Sound Levels	90
Sound Pressure Level	90
NC Curves.....	91
Sound Power	92
NR Curves.....	93
Refrigerant Cycle Diagrams.....	94
Parts of Outdoor Unit (HP)	94
Parts of Outdoor Unit (HR)	97
Dimensional Drawings.....	100
Wind/Snow Baffle Installation (optional)	103



System Features

- Individual modules are available as standard heat pump or simultaneous heating and cooling (heat recovery) configuration; units can be combined as double or triple modules for larger capacity requirements.
- 3rd generation compressor technology features all inverter compressors for superior efficiency and reliability.
- Asymmetric scroll is designed to minimize frictional loss.
- Dual inverter compressors (available in many models) are designed to equally share load for higher reliability.
- Improved vapor injection system increases refrigerant flow rate up to 20% for superior heating performance.
- Intercooler uses a plate heat exchanger for improved heating and cooling efficiency.
- 8,400 RPM (maximum speed) compressors assures quick start cooling and heating performance.
- Auto oil balancing eliminates the need for an oil balancing pipe.
- Compressor inverter drives are liquid cooled for improved reliability.
- Longer pipe lengths are the result of large oil storage capacity and low oil circulation rate.
- Total harmonic distortion is reduced through adaptive sine wave control.
- Refrigerant pump down and pump out facilitates maintenance and repair.
- Automatic refrigerant balancing between indoor units optimize refrigerant distribution for better comfort and performance.
- Optional quiet operation mode for reduced sound levels at night.
- Auto snow blowing function removes accumulated snow when conditions require it.
- Special hydrophilic heat exchanger coating minimizes frost build up on the outdoor coils and facilitates the defrost cycle.
- Anti-corrosion finish provides added protection in harsh environments.
- Four and six port mode control units are light and compact. Distributed installation flexibility provides superior performance during simultaneous heating and cooling operation.
- VRF systems feature self-diagnosis, including system monitoring and error code reporting.



Model Number Description

4	T	V	R	0	0	9	6	B	3	0	0	N	B	A
1	2	3	4	5	6	7	8	9	10	11	12	13	14	15

DIGIT 1 = Refrigerant

4 = R-410A

DIGIT 2 = Brand name

T = Trane

DIGIT 3 = System type

V = Variable Refrigerant Flow

**DIGIT 4 = Functional type
outdoor unit**

H = Heat Pump, DC Inverter (VRF)

R = Heat Recovery (three pipe), DC Inverter

DIGIT 5 = Special application

0 = Standard

DIGIT 6, 7, 8 = Nominal capacity (Btu/h x 1,000)

072 = 72,000 Btu/h (VRF)

096 = 96,000 Btu/h (VRF)

120 = 120,000 Btu/h (VRF)

144 = 144,000 Btu/h (VRF)

168 = 168,000 Btu/h (VRF)

192 = 192,000 Btu/h (VRF)

DIGIT 9 = Major development sequence

B = Second development sequence

DIGIT 10 = Electric power supply characteristics

3 = 208–230/60/3

4 = 460/60/3

DIGIT 11 = Reserved for future use

0 = Not currently used

DIGIT 12 = Miscellaneous digit

0 = Not currently used

DIGIT 13 = Region of sale

N = North America (VRF)

DIGIT 14 = Minor design sequence

A = First design sequence

B = Second design sequence

C = Third design sequence

DIGIT 15 = Service digit (not used for ordering)

A = First sequence

B = Second sequence



System Combination Line-Up

Table 1. Outdoor unit combinations: 6–24 ton capacity

Capacity		6 ton	8 ton	10 ton	12 ton	14 ton	16 ton	18 ton	20 ton	22 ton	24 ton
Outdoor unit combination number		4TV*0072	4TV*0096	4TV*0120	4TV*0144	4TV*0168	4TV*0192	4TV*0216	4TV*0240	4TV*0264	4TV*0288
Total number of individual outdoor units		1	1	1	1	1	1	2	2	2	2
Combined outdoor unit	4TV*0072	1						1	1	1	
	4TV*0096		1								
	4TV*0120			1							
	4TV*0144				1			1			2
	4TV*0168					1			1		
	4TV*0192						1			1	
Nominal Capacity	Cooling (Btu/h)	72000	96000	120000	144000	168000	192000	216000	240000	264000	288000
	Heating (Btu/h)	81000	108000	135000	162000	189000	216000	243000	270000	297000	324000
Rated Capacity	Cooling (Btu/h)	69000	92000	114000	138000	160000	184000	206000	228000	252000	276000
	Heating (Btu/h)	77000	103000	129000	154000	180000	206000	230000	258000	282000	308000
Total capacity of connected indoor units (cooling)	Minimum (Btu/h)	36000	48000	60000	72000	84000	96000	108000	120000	132000	144000
	Maximum (Btu/h)	93600	124800	156000	187200	218400	249600	280800	312000	343200	374400
Maximum quantity of connectable indoor units		12	16	20	25	29	33	37	41	45	49









Table 2. Outdoor unit combinations: 26–44 ton capacity

Capacity		26 ton	28 ton	30 ton	32 ton	34 ton	36 ton	38 ton	40 ton	42 ton	44 ton
Model name for Combination		4TV* 0312	4TV* 0336	4TV* 0360	4TV* 0384	4TV* 0408	4TV* 0432	4TV* 0456	4TV* 0480	4TV* 0504	4TV* 0528
Total number of individual outdoor units		2	2	2	2	3	3	3	3	3	3
Combined outdoor unit	4TV*0072					1					
	4TV*0096										
	4TV*0120							1			
	4TV*0144	1				1	3		1		
	4TV*0168	1	2	1				2	2	3	2
	4TV*0192			1	2	1					1
Nominal capacity	Cooling (Btu/h)	312000	336000	360000	384000	408000	432000	456000	480000	504000	528000
	Heating (Btu/h)	351000	378000	405000	432000	459000	486000	513000	540000	567000	594000
Rated capacity	Cooling (Btu/h)	298000	320000	344000	366000	390000	415000	435000	455000	480000	500000
	Heating (Btu/h)	334000	360000	386000	410000	435000	460000	490000	510000	535000	560000
Total capacity of indoor units (cooling)	Minimum (Btu/h)	156000	168000	180000	192000	204000	216000	228000	240000	252000	264000
	Maximum (Btu/h)	405600	436800	468000	499200	530400	561600	592800	624000	655200	686400
Maximum quantity of connectable indoor units		54	58	62	64	64	64	64	64	64	64





Products

Application Matrix

Type		Capacity (MBH)															
		7.5	9.0	9.5	12	15	18	20	24	27	30	36	42	48	60	76.8	96
1-way cassette		X		X	X												
4-way cassette			X		X		X		X		X	X		X			
Mini 4-way cassette				X	X		X	X									
Slim duct		X		X	X		X		X		X	X		X			
MSP duct		X		X	X	X	X		X	X	X	X		X			
HSP duct												X		X		X	X
Convertible ceiling/floor							X		X								
High Wall		X		X	X		X	X	X								
Convertible AHU									X		X	X	X	X	X		

Controls

Family	Description	Model Number
Zone Controllers	Wireless Remote Control <ul style="list-style-type: none"> • Mode: Heat/Cool/Auto/Off • Fan: Auto/High/Med/Low • Service Indicator 	TVCTRLTRDH00UT
	Simple Touch Remote Control <ul style="list-style-type: none"> • Mode: Heat/Cool/Auto/Off • Fan: Auto/High/med/Low • Service indicator 	TVCTRLTWR0002T
	Wired Remote Control <ul style="list-style-type: none"> • Mode: Heat/Cool/Auto/Off • Fan: Auto/High/Med/Low • Programmable • Service Indicator 	TVCTRLTWRWD01T
	Duct Signal Receiver	TVCTRLTRKA10N0
Centralized Control Systems	VRF Central On/Off Control	TVCTRLTCMA202D
	VRF Touch Screen Control	TVCTRLTCMA300T
	Mode Select Switch	TCVTRLTCMC2000
Integrated System Management	VRF System Controller	TVCTRLTIMD00A0
	VRF Enterprise Management Software	TVCTRLTSTP3P00
	VRF Power Meter Interface (PIM)	TVCTRLTIMB16A0
Building Management System Gateways	VRF System Controller+BACnet® Note: This controller enables BACnet integration.	TVCTRLTIMB17A0
Interface Modules	VRF External Contact Interface Module/Auxiliary Heat Module	TVCTRLTIMB14A0
	VRF Multi-function Control (MFC)	TVCTRLTC210N00
	VRF MFC Enclosure	TVCTRLTC210BOX
Sensors	VRF External Room Temperature Sensor	TVCTRLTRWTA000
	VRF Motion Sensor Mini 4-Way	MOTIONSEN4TVB
Commissioning Utility Kits	VRF Technician Utilities Tool (TUT)	TVCTRLTIMC0300



Products

Accessories

Family	Description	Model Number
Indoor Y-joints	51 MBH and below	4YDK1509B0051A
	52-136 MBH	4YDK2512B0138A
	137-154 MBH	4YDK2812B0160A
	155-240 MBH	4YDK2815B0240A
	241-336 MBH	4YDK3419B0336A
	337-461 MBH	4YDK4119B0468A
	Above 461 MBH	4YDK4422B0999A
Indoor Y-joints for heat recovery (high-pressure gas)	76 MBH and below	4YDK1500B0080A
	77-240 MBH	4YDK2500B0240A
	241-461 MBH	4YDK3100B0468A
	Above 461 MBH	4YDK3800B0999A
Distribution headers	154 MBH and below (max. number of connections: 4)	4HJK2512B0159A
	240 MBH and below (max. number of connections: 8)	4HJK3115B0241A
	Above 240 MBH (max. number of connections: 8)	4HJK3819B0998A
Outdoor Y-joints	456 MBH and below	4TDK3819B0000A
	Above 456 MBH	4TDK4422B0999A
Outdoor Y-joints for heat recovery (high-pressure gas)	456 MBH and below	4TDK3100B0000A
	Above 456 MBH	4TDK3800B0999A
AHU Kits	24-30 MBH	4EEVAKA40K1025
	48-60 MBH	4EEVAKA40K1050
	72-90 MBH	4EEVAKA64K1075
	96-119 MBH	4EEVAKA64K1100
Mode Control Units (MCUs) (for simultaneous heating and cooling applications)	Maximum connectable IDUs: 6 (maximum capacity of IDUs: 180 MBH)	4MCUCUY6NCE000
	Maximum connectable IDUs: 4 (maximum capacity of IDUs: 120 MBH)	4MCUCUY4NCE000
	Maximum connectable IDUs: 2 (maximum capacity of IDUs: 192 MBH)	4MCUCUY2NCE000
Ball Valves	1/2 inch Ball Valve Flare	BVALVE12FLARE1
	1/4 inch Ball Valve Flare	BVALVE14FLARE1
	3/8 inch Ball Valve Flare	BVALVE38FLARE1
	5/8 inch Ball Valve Flare	BVALVE58FLARE1
	3/4 inch Ball Valve Sweat	BAVALVE34SWEAT1
	7/8 inch Ball Valve Sweat	BAVALVE78SWEAT1
Pressure Differential Module (for high-rise applications)	Pressure Differential Module 6/8/10 Ton	MXD-A12K2A
	Pressure Differential Module 12/14/16 Ton	MXD-A38K2A
Hail Guards	4TVH/R0072	TVRGARD001A
	4TVH/R00096-192	TVRGARD002A
	4TVH0036/48/53	TVRGARD003A

Family	Description	Model Number
Wind Baffles	4TVH/R0072	TVRWINDSNOW001
	4TVH/R0096-0192	TVRWINDSNOW002
Condenser Fan Discharge Duct	4TVH/R0072	TVRODUDUCT0001
	4TVH/R0096-0192	TVRODUDUCT0002



Product Specifications

Table 3. 208-230 V heat pump single modules: 6-10 ton capacity

Model Name		4TVH0072B300NB		4TVH0096B300NB		4TVH0120B300NB			
Power Supply		208-230/60/3		208-230/60/3		208-230/60/3			
Nominal Tons		6.0		8.0		10.0			
System Type		Ducted		Non-Ducted		Ducted		Non-Ducted	
		Capacity (Nominal) ¹	Cooling	Btu/h	72,000	72,000	96,000	96,000	120,000
	Heating	Btu/h	81,000	81,000	108,000	108,000	135,000	135,000	
	Cooling	Btu/h	69,000	69,000	92,000	92,000	114,000	114,000	
	High Temp Heating	Btu/h	77,000	77,000	103,000	103,000	129,000	129,000	
	Low Temp Heating	Btu/h	51,000	51,000	67,000	67,000	84,000	84,000	
	EER	-	11.50	14.60	11.60	15.00	11.90	13.10	
	IEER	-	22.50	33.00	23.00	38.20	23.00	28.70	
	COP @ 47°F	-	3.46	4.35	3.60	4.46	3.54	3.97	
	COP @ 17°F	-	2.49	2.80	2.47	2.90	2.58	2.62	
	SCHE	-	-	-	-	-	-	-	
	MCA	A	28	37.8	43.0				
	MOP	A	35	50	50				
	SCCR	kA	5	5	5				
	Type (Qty.)	-	SSC Scroll (1)	SSC Scroll (2)	SSC Scroll (2)				
	Model Name	-	DS-GB052FBV/ASG	DS-GB052FBV/ASG x 2	DS-GB052FBV/ASG x 2				
	Oil	Type	PVE	PVE	PVE				
	Initial Charge	fl. oz.	131.9	209.6	209.6				
	Type (Qty.)	-	Propeller (1)	Propeller (2)	Propeller (2)				
	Output (Each)	W	630	620	620				
	Airflow Rate	CFM	7,240	9,180	9,180				
	External Static Pressure	in. WG	0.31	0.31	0.31				

Table 3. 208-230 V heat pump single modules: 6-10 ton capacity (continued)

Model Name	4TVH0072B300NB		4TVH0096B300NB		4TVH0120B300NB		
Power Supply	208-230/60/3		208-230/60/3		208-230/60/3		
Nominal Tons	6.0		8.0		10.0		
System Type	Ducted	Non-Ducted	Ducted	Non-Ducted	Ducted	Non-Ducted	
Piping Connections	Liquid Pipe	dia. in.	3/8 Braze	3/8 Braze	1/2 Braze		
	Gas Pipe	dia. in.	3/4 Braze	7/8 Braze	1-1/8 Braze		
	High Pressure Gas Pipe (for HR)	Installation	dia. in.	N/A	N/A	N/A	
		Limits	ft	656 (722)	656 (722)	656 (722)	
Indoor Unit Connections	Max Length ³	ft	361 (131)	361 (131)	361 (131)		
	Max Height ⁴	ft					
Total capacity (cooling)	Number of connectable indoor units	-	12	16	20		
	Total capacity (cooling)	Btu/h	36,000 - 93,600	48,000 - 124,800	60,000 - 156,000		
Refrigerant	Type	-	R410A	R410A	R410A		
	Factory charge	lbs.	12.1	16.3	16.3		
Sound ⁵	Sound pressure	dB(A)	60	61	61		
	Sound power	dB(A)	77	81	81		
External Dimensions	Net weight	lbs.	425	624	624		
	Shipping weight	lbs.	461	666	666		
	Net dimensions (WxHxD)	in.	34.65 x 66.73 x 30.12	50.98 x 66.73 x 30.12	50.98 x 66.73 x 30.12		
Operating Temp Range	Shipping dimensions (WxHxD)	in.	37.32 x 75.29 x 32.76	53.66 x 75.29 x 32.76	53.66 x 75.29 x 32.76		
	Cooling	°F	23 to 120	23 to 120	23 to 120		
Heating	°F	-13 to 75	-13 to 75	-13 to 75			

Notes:

- Nominal capacity based on 25 ft (7.6 m) of equivalent refrigerant piping with 0 ft level difference.
 - Cooling:** Indoor temperature 80°F DB, 67°F WB/Outdoor temperature 95°F DB, 75°F WB
 - Heating:** Indoor temperature 70°F DB, 60°F WB/Outdoor temperature 47°F DB, 43°F WB
- Rated per AHRI-1230 Standard conditions
- Actual length (equivalent length in parenthesis)
- If the outdoor unit is installed above the indoor unit, the allowable height difference is 361 ft (110 m). If the outdoor unit is installed below the indoor unit, the allowable height difference is 131 ft (40 m).
- Sound pressure was acquired in a dead room. Actual noise level may be different depending on installation conditions.

Product Specifications
Table 4. 208–230 V heat pump single modules: 12–16 ton capacity

Model Name		4TVH0144B300NB		4TVH0168B300NC		4TVH0192B300NC	
Power Supply		208-230/60/3		208-230/60/3		208-230/60/3	
Nominal Tons		12.0		14.0		16.0	
System Type		Ducted		Ducted		Ducted	
		Non-Ducted		Non-Ducted		Non-Ducted	
Capacity (Nominal) ¹	Cooling	Btu/h	144,000	144,000	168,000	168,000	192,000
	Heating	Btu/h	162,000	162,000	189,000	189,000	216,000
Capacity (Rated) ²	Cooling	Btu/h	138,000	138,000	160,000	160,000	184,000
	High Temp Heating	Btu/h	154,000	154,000	180,000	180,000	206,000
	Low Temp Heating	Btu/h	100,000	100,000	118,000	118,000	134,000
Performance	EER	-	11.70	12.00	10.60	10.90	10.60
	IEER	-	21.60	26.50	20.80	24.50	21.00
	COP @ 47°F	-	3.54	3.81	3.21	3.65	3.20
	COP @ 17°F	-	2.42	2.55	2.25	2.50	2.20
	SCHE	-	-	-	-	-	-
Power	MCA	A	52.6	66.0	73.0	73.0	
	MOP	A	70	80	90	90	
	SCCR	kA	5	5	5	5	
Compressor	Type (Qty.)	-	SSC Scroll (2)	SSC Scroll (2)	SSC Scroll (2)	SSC Scroll (2)	
	Model Name	-	DS-GB052FBVAVG x 2	DS-GB052FBVAVG x 2	DS-GB052FBVAVG x 2	DS-GB052FBVAVG x 2	
	Oil	Type	PVE	PVE	PVE	PVE	
	Initial Charge	fl. oz.	209.6	209.6	209.6	209.6	
Fan	Type (Qty.)	-	Propeller (2)	Propeller (2)	Propeller (2)	Propeller (2)	
	Output (Each)	W	620	620	620	620	
	Airflow Rate	CFM	9,535	10,950	10,950	10,950	
	External Static Pressure	in. WG	0.31	0.31	0.31	0.31	

Table 4. 208–230 V heat pump single modules: 12–16 ton capacity (continued)

Model Name		4TVH0144B300NB		4TVH0168B300NC		4TVH0192B300NC			
Power Supply		208-230/60/3		208-230/60/3		208-230/60/3			
Nominal Tons		12.0		14.0		16.0			
System Type		Ducted		Non-Ducted		Ducted		Non-Ducted	
Piping Connections	Liquid Pipe	dia. in.	1/2 Braze	5/8 Braze	5/8 Braze	5/8 Braze	5/8 Braze		
	Gas Pipe	dia. in.	1–1/8 Braze	1–1/8 Braze	1–1/8 Braze	1–1/8 Braze	1–1/8 Braze		
	High Pressure Gas Pipe (for HR)	dia. in.	N/A	N/A	N/A	N/A	N/A		
	Installation Limits	Max Length ³	ft	656 (722)	656 (722)	656 (722)	656 (722)		
Indoor Unit Connections	Max Height ⁴	ft	361 (131)	361 (131)	361 (131)	361 (131)	361 (131)		
	Number of Connectable Indoor Units	-	25	29	29	33	33		
Total Capacity (Cooling)		Btu/h	72,000–187,200	84,000–218,400	84,000–218,400	96,000–249,600	96,000–249,600		
Refrigerant		Type	R410A	R410A	R410A	R410A	R410A		
Sound ⁵	Factory Charge	lbs.	19.2	24.3	24.3	24.3	24.3		
	Sound Pressure	dB(A)	62	63	63	64	64		
	Sound Power	dB(A)	83	85	85	86	86		
	Net Weight	lbs.	657	717	717	734	734		
External Dimensions	Shipping Weight	lbs.	699	754	754	772	772		
	Net Dimensions (WxHxD)	in.	50.98 x 66.73 x 30.12	50.98 x 66.73 x 30.12	50.98 x 66.73 x 30.12	50.98 x 66.73 x 30.12	50.98 x 66.73 x 30.12		
	Shipping Dimensions (WxHxD)	in.	53.66 x 75.29 x 32.76	53.66 x 75.29 x 32.76	53.66 x 75.29 x 32.76	53.66 x 75.29 x 32.76	53.66 x 75.29 x 32.76		
Operating Temp Range	Cooling	°F	23 to 120	23 to 120	23 to 120	23 to 120	23 to 120		
	Heating	°F	-13 to 75	-13 to 75	-13 to 75	-13 to 75	-13 to 75		

Notes:

- Nominal capacity based on 25 ft (7.6 m) of equivalent refrigerant piping with 0 ft level difference.
 - Cooling:** Indoor temperature 80°F DB, 67°F WB/Outdoor temperature 95°F DB, 75°F WB
 - Heating:** Indoor temperature 70°F DB, 60°F WB/Outdoor temperature 47°F DB, 43°F WB
- Rated per AHRI-1230 Standard conditions
- Actual length (equivalent length in parenthesis)
- If the outdoor unit is installed above the indoor unit, the allowable height difference is 361 ft (110 m). If the outdoor unit is installed below the indoor unit, the allowable height difference is 131 ft (40 m).
- Sound pressure was acquired in a dead room. Actual noise level may be different depending on installation conditions.

Table 5. 208-230 V heat pump dual modules: 18–24 ton capacity

Model Name		4TVH0216B300NC		4TVH0240B300NC		4TVH0264B300NC		4TVH0288B300NC	
Individual Models		4TVH0072B300NB + 4TVH0144B300NB		4TVH0072B300NB + 4TVH0168B300NC		4TVH0072B300NB + 4TVH0192B300NC		2x 4TVH0144B300NB	
Power Supply		208-230/60/3		208-230/60/3		208-230/60/3		208-230/60/3	
Nominal Tons		18.0		20.0		22.0		24.0	
System Type		Ducted	Non-Ducted	Ducted	Non-Ducted	Ducted	Non-Ducted	Ducted	Non-Ducted
		Capacity (Nominal) ¹	Cooling	216,000	216,000	240,000	240,000	264,000	264,000
Capacity (Rated) ²	Heating	243,000	243,000	270,000	270,000	297,000	297,000	324,000	324,000
	Cooling	206,000	206,000	228,000	228,000	252,000	252,000	276,000	276,000
Performance	High Temp Heating	230,000	230,000	258,000	258,000	282,000	282,000	308,000	308,000
	Low Temp Heating	150,000	150,000	168,000	168,000	184,000	184,000	200,000	200,000
AHRI -1230 Efficiency Ratings ²	EER	-	10.60	10.60	10.60	10.10	10.10	10.00	12.00
	IEER	-	20.50	20.10	22.00	19.60	21.90	21.60	22.00
	COP@ 47°F	-	3.34	3.20	3.51	3.20	3.50	3.32	3.58
	COP@ 17°F	-	2.31	2.40	2.38	2.17	2.31	2.35	2.48
	SCHE	-	-	-	-	-	-	-	-
Power	MCA	A							
	MOP	A							
	SCCR	kA							
Compressor	Type (Qty.)	SSC Scroll (3)		SSC Scroll (3)		SSC Scroll (3)		SSC Scroll (4)	
	Model Name	DS-GB052FBVAVSG x 3		DS-GB052FBVAVSG x 3		DS-GB052FBVAVSG x 1 + DS4GJ5066EVAVSG x 2		DS-GB052FBVAVSG x 4	
Oil	Type	PVE		PVE		PVE		PVE	
	Initial Charge	341.5		341.5		341.5		419.2	

Each individual outdoor unit requires a separate electrical connection. Refer to the electrical data for each individual outdoor unit.

Table 5. 208-230 V heat pump dual modules: 18–24 ton capacity (continued)

Model Name	4TVH0216B300NC		4TVH0240B300NC		4TVH0264B300NC		4TVH0288B300NC			
	Ducted	Non-Ducted	Ducted	Non-Ducted	Ducted	Non-Ducted	Ducted	Non-Ducted		
Individual Models	4TVH0072B300NB + 4TVH0144B300NB		4TVH0072B300NB + 4TVH0168B300NC		4TVH0072B300NB + 4TVH0192B300NC		2x 4TVH0144B300NB			
Power Supply	208-230/60/3		208-230/60/3		208-230/60/3		208-230/60/3			
Nominal Tons	18.0		20.0		22.0		24.0			
System Type	Ducted	Non-Ducted	Ducted	Non-Ducted	Ducted	Non-Ducted	Ducted	Non-Ducted		
Fan	Type (Qty.)	Propeller (3)		Propeller (3)		Propeller (3)		Propeller (4)		
	Output (Each)	630 + (620 x 2)		630 + (620 x 2)		630 + (620 x 2)		(620 x 2) + (620 x 2)		
	Airflow Rate	7,240 + 9,535		7,240 + 10,950		7,240 + 10,950		9,535 x 2		
	External Static Pressure	0.31		0.31		0.31		0.31		
	Liquid Pipe	5/8 Braze		5/8 Braze		3/4 Braze		3/4 Braze		
Piping Connections	Gas Pipe	1-1/8 Braze		1-1/8 Braze		1-3/8 Braze		1-3/8 Braze		
	High Pressure Gas Pipe (for HR)	N/A		N/A		N/A		N/A		
	Installation Limits	Max Length ³	656 (722)		656 (722)		656 (722)		656 (722)	
		Max Height ⁴	361 (131)		361 (131)		361 (131)		361 (131)	
	Number of Connectable Indoor Units	37		41		45		49		
Refrigerant	Total Capacity (Cooling)	108,000 - 280,800		120,000 - 312,000		132,000 - 343,200		144,000 - 374,400		
	Type	R410A		R410A		R410A		R410A		
	Factory Charge	31.3		36.4		36.4		38.4		
	Sound Pressure	64		65		65		65		
	Sound Power	84		86		87		86		

Table 5. 208-230 V heat pump dual modules: 18–24 ton capacity (continued)

Model Name	4TVH0216B300NC	4TVH0240B300NC	4TVH0264B300NC	4TVH0288B300NC	
Individual Models	4TVH0072B300NB + 4TVH0144B300NB	4TVH0072B300NB + 4TVH0168B300NC	4TVH0072B300NB + 4TVH0192B300NC	2x 4TVH0144B300NB	
Power Supply	208-230/60/3	208-230/60/3	208-230/60/3	208-230/60/3	
Nominal Tons	18.0	20.0	22.0	24.0	
System Type	Ducted	Ducted	Ducted	Ducted	
	Non-Ducted	Non-Ducted	Non-Ducted	Non-Ducted	
External Dimensions	Net Weight	lbs. 425 + 657	lbs. 425 + 716	lbs. 425 + 734	
	Shipping Weight	lbs. 461 + 699	lbs. 461 + 754	lbs. 461 + 772	
	Net Dimensions (WxHxD)	in. 34.65 x 66.73 x 30.12 + 50.98 x 66.73 x 30.12	in. 34.65 x 66.73 x 30.12 + 50.98 x 66.73 x 30.12	in. 34.65 x 66.73 x 30.12 + 50.98 x 66.73 x 30.12	in. (50.98 x 66.73 x 30.12) x 2
	Shipping Dimensions (WxHxD)	in. 37.32 x 75.28 x 32.76 + 53.66 x 75.28 x 32.76	in. 37.32 x 75.28 x 32.76 + 53.66 x 75.28 x 32.76	in. 37.32 x 75.28 x 32.76 + 53.66 x 75.28 x 32.76	in. (53.66 x 75.28 x 32.76) x 2
Operating Temp Range	Cooling	°F 23 to 120	°F 23 to 120	°F 23 to 120	
	Heating	°F -13 to 75	°F -13 to 75	°F -13 to 75	

Notes:

- Nominal capacity based on 25 ft (7.6 m) of equivalent refrigerant piping with 0 ft level difference.
 - Cooling:** Indoor temperature 80°F DB, 67°F WB/Outdoor temperature 95°F DB, 75°F WB
 - Heating:** Indoor temperature 70°F DB, 60°F WB/Outdoor temperature 47°F DB, 43°F WB
- Rated per AHRI-1230 Standard conditions
- Actual length (equivalent length in parenthesis)
- If the outdoor unit is installed above the indoor unit, the allowable height difference is 361 ft (110 m). If the outdoor unit is installed below the indoor unit, the allowable height difference is 131 ft (40 m).
- Sound pressure was acquired in a dead room. Actual noise level may be different depending on installation conditions.

Table 6. 208-230 V heat pump dual modules: 26–32 ton capacity

Model Name		4TVH0312B300NC		4TVH0336B300NC		4TVH0360B300NC		4TVH0384B300NC			
Individual Models		4TVH0144B300NB + 4TVH0168B300NC		2x 4TVH0168B300NC		4TVH0168B300NC + 4TVH0192B300NC		2x 4TVH0192B300NC			
Power Supply		208-230/60/3		208-230/60/3		208-230/60/3		208-230/60/3			
Nominal Tons		26.0		28.0		30.0		32.0			
System Type		Ducted		Non-Ducted		Ducted		Non-Ducted			
Performance	Capacity (Nominal) ¹	Cooling	Btu/h	312,000	312,000	336,000	336,000	360,000	288,000	384,000	
		Heating	Btu/h	351,000	351,000	378,000	378,000	405,000	405,000	432,000	
		Cooling	Btu/h	298,000	298,000	320,000	320,000	344,000	344,000	366,000	
	Capacity (Rated) ²	High Temp Heating	Btu/h	334,000	334,000	360,000	360,000	386,000	386,000	410,000	
		Low Temp Heating	Btu/h	218,000	218,000	234,000	234,000	250,000	250,000	268,000	
	AHRI -1230 Efficiency Ratings ²	EER	-	9.90	9.90	9.80	9.80	9.80	9.70	9.70	9.70
		IEER	-	20.10	20.40	19.40	20.30	18.90	20.00	19.50	19.50
		COP@ 47°F	-	3.20	3.24	3.20	3.20	3.20	3.20	3.20	3.20
		COP@ 17°F	-	2.41	2.46	2.38	2.43	2.38	2.42	2.42	2.41
		SCHE	-	-	-	-	-	-	-	-	-
Power	MCA	A									
	MOP	A									
	SCCR	kA									
Compressor	Type (Qty.)	-	SSC Scroll (4)	SSC Scroll (4)	SSC Scroll (4)	SSC Scroll (4)	SSC Scroll (4)	SSC Scroll (4)	SSC Scroll (4)	SSC Scroll (4)	
	Model Name	-	DS-GB052FBVAVSG x 4	DS-GB052FBVAVSG x 4	DS-GB052FBVAVSG x 4	DS-GB052FBVAVSG x 2 + DS4GJ5066EVAVSG x 2	DS-GB052FBVAVSG x 4	DS-GB052FBVAVSG x 2 + DS4GJ5066EVAVSG x 2	DS4GJ5066EVAVSG x 4	DS4GJ5066EVAVSG x 4	
	Oil	Type	-	PVE	PVE	PVE	PVE	PVE	PVE	PVE	
	Initial Charge	fl. oz.	419.2	419.2	419.2	419.2	419.2	419.2	419.2	419.2	

Each individual outdoor unit requires a separate electrical connection. Refer to the electrical data for each individual outdoor unit.



Product Specifications

Table 6. 208-230 V heat pump dual modules: 26–32 ton capacity (continued)

Model Name	4TVH0312B300NC	4TVH0336B300NC	4TVH0360B300NC	4TVH0384B300NC
Individual Models	4TVH0144B300NB + 4TVH0168B300NC	2x 4TVH0168B300NC	4TVH0168B300NC + 4TVH0192B300NC	2x 4TVH0192B300NC
Power Supply	208-230/60/3	208-230/60/3	208-230/60/3	208-230/60/3
Nominal Tons	26.0	28.0	30.0	32.0
System Type	Ducted	Ducted	Ducted	Ducted
	Non-Ducted	Non-Ducted	Non-Ducted	Non-Ducted
Type (Qty.)	Propeller (4)		Propeller (4)	
Output (Each)	(620 x 2) + (620 X 2)		(620 x 2) + (620 X 2)	
Airflow Rate	9535 + 10,950		10,950 x 2	
External Static Pressure	0.31		0.31	
Liquid Pipe	3/4 Braze		3/4 Braze	
Gas Pipe	1-3/8 Braze		1-5/8 Braze	
HIGH PRESSURE GAS PIPE (for HR)	N/A		N/A	
Installation Limits	Max Length ³	656 (722)		656 (722)
	Max Height ⁴	361 (131)		361 (131)
Number of Connectable Indoor Units	54		62	
Total Capacity (Cooling)	156,000 - 405,600		168,000 - 436,800	
Type	R410A		R410A	
Factory Charge	43.4		48.5	
Sound Pressure	66		66	
Sound Power	87		87	
	156,000 - 405,600		180,000 - 468,000	
	R410A		R410A	
	43.4		48.5	
	66		66	
	87		87	
	54		62	
	156,000 - 405,600		168,000 - 436,800	
	R410A		R410A	
	43.4		48.5	
	66		66	
	87		87	
	54		62	
	156,000 - 405,600		168,000 - 436,800	
	R410A		R410A	
	43.4		48.5	
	66		66	
	87		87	
	54		62	
	156,000 - 405,600		168,000 - 436,800	
	R410A		R410A	
	43.4		48.5	
	66		66	
	87		87	
	54		62	
	156,000 - 405,600		168,000 - 436,800	
	R410A		R410A	
	43.4		48.5	
	66		66	
	87		87	
	54		62	
	156,000 - 405,600		168,000 - 436,800	
	R410A		R410A	
	43.4		48.5	
	66		66	
	87		87	
	54		62	
	156,000 - 405,600		168,000 - 436,800	
	R410A		R410A	
	43.4		48.5	
	66		66	
	87		87	
	54		62	
	156,000 - 405,600		168,000 - 436,800	
	R410A		R410A	
	43.4		48.5	
	66		66	
	87		87	
	54		62	
	156,000 - 405,600		168,000 - 436,800	
	R410A		R410A	
	43.4		48.5	
	66		66	
	87		87	
	54		62	
	156,000 - 405,600		168,000 - 436,800	
	R410A		R410A	
	43.4		48.5	
	66		66	
	87		87	
	54		62	
	156,000 - 405,600		168,000 - 436,800	
	R410A		R410A	
	43.4		48.5	
	66		66	
	87		87	
	54		62	
	156,000 - 405,600		168,000 - 436,800	
	R410A		R410A	
	43.4		48.5	
	66		66	
	87		87	
	54		62	
	156,000 - 405,600		168,000 - 436,800	
	R410A		R410A	
	43.4		48.5	
	66		66	
	87		87	
	54		62	
	156,000 - 405,600		168,000 - 436,800	
	R410A		R410A	
	43.4		48.5	
	66		66	
	87		87	
	54		62	
	156,000 - 405,600		168,000 - 436,800	
	R410A		R410A	
	43.4		48.5	
	66		66	
	87		87	
	54		62	
	156,000 - 405,600		168,000 - 436,800	
	R410A		R410A	
	43.4		48.5	
	66		66	
	87		87	
	54		62	
	156,000 - 405,600		168,000 - 436,800	
	R410A		R410A	
	43.4		48.5	
	66		66	
	87		87	
	54		62	
	156,000 - 405,600		168,000 - 436,800	
	R410A		R410A	
	43.4		48.5	
	66		66	
	87		87	
	54		62	
	156,000 - 405,600		168,000 - 436,800	
	R410A		R410A	
	43.4		48.5	
	66		66	
	87		87	
	54		62	
	156,000 - 405,600		168,000 - 436,800	
	R410A		R410A	
	43.4		48.5	
	66		66	
	87		87	
	54		62	
	156,000 - 405,600		168,000 - 436,800	
	R410A		R410A	
	43.4		48.5	
	66		66	
	87		87	
	54		62	
	156,000 - 405,600		168,000 - 436,800	
	R410A		R410A	
	43.4		48.5	
	66		66	
	87		87	
	54		62	
	156,000 - 405,600		168,000 - 436,800	
	R410A		R410A	
	43.4		48.5	
	66		66	
	87		87	
	54		62	
	156,000 - 405,600		168,000 - 436,800	
	R410A		R410A	
	43.4		48.5	
	66		66	
	87		87	
	54		62	
	156,000 - 405,600		168,000 - 436,800	
	R410A		R410A	
	43.4		48.5	
	66		66	
	87		87	
	54		62	
	156,000 - 405,600		168,000 - 436,800	
	R410A		R410A	
	43.4		48.5	
	66		66	
	87		87	
	54		62	
	156,000 - 405,600		168,000 - 436,800	
	R410A		R410A	
	43.4		48.5	
	66		66	
	87		87	
	54		62	
	156,000 - 405,600		168,000 - 436,800	
	R410A		R410A	
	43.4		48.5	
	66		66	
	87		87	
	54		62	
	156,000 - 405,600		168,000 - 436,800	
	R410A		R410A	
	43.4		48.5	
	66		66	
	87		87	
	54		62	
	156,000 - 405,600		168,000 - 436,800	
	R410A		R410A	
	43.4		48.5	
	66		66	
	87		87	
	54		62	
	156,000 - 405,600		168,000 - 436,800	
	R410A		R410A	
	43.4		48.5	
	66		66	
	87		87	
	54		62	
	156,000 - 405,600		168,000 - 436,800	
	R410A		R410A	
	43.4		48.5	
	66		66	
	87		87	
	54		62	
	156,000 - 405,600		168,000 - 436,800	
	R410A		R410A	
	43.4		48.5	
	66		66	
	87		87	
	54		62	
	156,000 - 405,600		168,000 - 436,800	
	R410A		R410A	
	43.4		48.5	
	66		66	
	87		87	
	54		62	
	156,000 - 405,600		168,000 - 436,800	
	R410A		R410A	
	43.4		48.5	
	66		66	
	87		87	
	54		62	
	156,000 - 405,600		168,000 - 436,800	
	R410A		R410A	
	43.4		48.5	
	66		66	
	87		87	
	54		62	
	156,000 - 405,600		168,000 - 436,800	
	R410A		R410A	
	43.4		48.5	
	66		66	
	87		87	
	54		62	
	156,000 - 405,600		168,000 - 436,800	
	R410A		R410A	
	43.4		48.5	
	66		66	
	87		87	
	54		62	
	156,000 - 405,600		168,000 - 436,800	
	R410A		R410A	
	43.4		48.5	
	66		66	
	87		87	
	54		62	
	156,000 - 405,600		168,000 - 436,800	
	R410A		R410A	
	43.4		48.5	
	66		66	
	87		87	
	54		62	
	156,000 - 405,600		168,000 - 436,800	
	R410A		R410A	
	43.4		48.5	
	66		66	
	87		87	
	54		62	
	156,000 - 405,600		168,000 - 436,800	
	R410A		R410A	
	43.4		48.5	
	66		66	
	87		87	
	54		62	
	156,000 - 405,600		168,000 - 436,800	
	R410A		R410A	
	43.4		48.5	
	66		66	
	87		87	
	54		62	
	156,000 - 405,600		168,000 - 436,800	
	R410A		R410A	
	43.4		48.5	
	66		66	
	87		87	
	54		62	
	156,000 - 405,600		168,000 - 436,800	
	R410A		R410A	
	43.4		48.5	
	66		66	
	87		87	
	54		62	
	156,000 - 405,600		168,000 - 436,800	
	R410A		R410A	
	43.4		48.	

Table 6. 208-230 V heat pump dual modules: 26–32 ton capacity (continued)

Model Name	4TVH0312B300NC	4TVH0336B300NC	4TVH0360B300NC	4TVH0384B300NC		
Individual Models	4TVH0144B300NB + 4TVH0168B300NC	2x 4TVH0168B300NC	4TVH0168B300NC + 4TVH0192B300NC	2x 4TVH0192B300NC		
Power Supply	208-230/60/3	208-230/60/3	208-230/60/3	208-230/60/3		
Nominal Tons	26.0	28.0	30.0	32.0		
System Type	Ducted	Non-Ducted	Ducted	Non-Ducted		
External Dimensions	Net Weight	lbs. 657 + 717	Ducted	717 x 2	Non-Ducted	734 x 2
	Shipping Weight	lbs. 699 + 754	Ducted	754 x 2	Non-Ducted	772 x 2
	Net Dimensions (WxHxD)	in. (50.98 x 66.73 x 30.12) x 2	Ducted	(50.98 x 66.73 x 30.12) x 2	Non-Ducted	(50.98 x 66.73 x 30.12) x 2
Operating Temp Range	Shipping Dimensions (WxHxD)	in. (53.66 x 75.28 x 32.76) x 2	Ducted	(53.66 x 75.28 x 32.76) x 2	Non-Ducted	(53.66 x 75.28 x 32.76) x 2
	Cooling	°F 23 to 120	Ducted	23 to 120	Non-Ducted	23 to 120
	Heating	°F -13 to 75	Ducted	-13 to 75	Non-Ducted	-13 to 75

Notes:

- Nominal capacity based on 25 ft (7.6 m) of equivalent refrigerant piping with 0 ft level difference.
 - Cooling:** Indoor temperature 80°F DB, 67°F WB/Outdoor temperature 95°F DB, 75°F WB
 - Heating:** Indoor temperature 70°F DB, 60°F WB/Outdoor temperature 47°F DB, 43°F WB
- Rated per AHRI-1230 Standard conditions
- Actual length (equivalent length in parenthesis)
- If the outdoor unit is installed above the indoor unit, the allowable height difference is 361 ft (110 m). If the outdoor unit is installed below the indoor unit, the allowable height difference is 131 ft (40 m).
- Sound pressure was acquired in a dead room. Actual noise level may be different depending on installation conditions.

Product Specifications
Table 7. 208 – 230 V heat pump triple modules: 34–38 ton capacity

Model Name	4TVH0408B300NC	4TVH0432B300NC	4TVH0456B300NC					
Individual Models	4TVH0072B300NB + 4TVH0144B300NB + 4TVH0192B300NC	3x 4TVH0144B300NB	4TVH0120B300NB + 2x 4TVH0168B300NC					
Power Supply	208-230/60/3	208-230/60/3	208-230/60/3					
Nominal Tons	34.0	36.0	38.0					
System Type	Ducted	Ducted	Non-Ducted					
Performance	Capacity (Nominal) ¹	Btu/h	408,000	408,000	432,000	432,000	456,000	
	Capacity (Rated) ²	Cooling	Btu/h	459,000	459,000	486,000	486,000	513,000
		Heating	Btu/h	390,000	390,000	415,000	415,000	435,000
		High Temp Heating	Btu/h	435,000	435,000	460,000	460,000	490,000
	Low Temp Heating	Btu/h	284,000	284,000	300,000	300,000	320,000	
	AHRI -1230 Efficiency Ratings ²	EER	-	9.80	9.80	9.60	9.60	9.70
		IEER	-	17.80	19.10	17.00	19.10	19.00
		COP @ 47° F	-	3.20	3.20	3.20	3.20	3.23
		COP @ 17° F	-	2.36	2.36	2.28	2.33	2.27
	SCHE	-	-	-	-	-	-	-
Power	MCA	A	Each individual outdoor unit requires a separate electrical connection. Refer to the electrical data for each individual outdoor unit.					
	MOP	A						
	SCCR	kA						
Compressor	Type (Qty.)	-	SSC Scroll (5)	SSC Scroll (6)	SSC Scroll (6)	SSC Scroll (6)		
	Model Name	-	DS-GB052FBVASG x 3 + DS4GJ5066EVASG x 2	DS-GB052FBVASG x 6	DS-GB052FBVASG x 6	DS-GB052FBVASG x 6		
	Oil	Type	-	PVE	PVE	PVE	PVE	
		Initial Charge	fl. oz.	551.1	628.8	628.8	628.8	

Table 7. 208 – 230 V heat pump triple modules: 34–38 ton capacity (continued)

Model Name		4TVH0408B300NC	4TVH0432B300NC	4TVH0456B300NC	
Individual Models		4TVH0072B300NB + 4TVH0144B300NB + 4TVH0192B300NC	3x 4TVH0144B300NB	4TVH0120B300NB + 2x 4TVH0168B300NC	
Power Supply		208-230/60/3			
Nominal Tons		38.0			
System Type		208-230/60/3			
Fan	Type (Qty.)	34.0		36.0	
		Ducted	Non-Ducted	Ducted	
Piping Connections	Output (Each)	Propeller (6)		Propeller (6)	
	Airflow Rate	630 + (620 x 2) + (620 X 2)		(620 x 2) + (620 x 2) + (620 X 2)	
	External Static Pressure	CFM		9,535 x 3	
	Liquid Pipe	in. WG		0.31	
	Gas Pipe	dia. in.		3/4 Braze	
	High Pressure Gas Pipe (for HR)	dia. in.		1-5/8 Braze	
	Installation Limits	Max Length ³	656 (722)		656 (722)
		Max Height ⁴	361 (131)		361 (131)
	Indoor Unit Connections	Number of connectable Indoor Units	64		64
	Refrigerant	Total Capacity (Cooling)	Btu/h		216,000 - 561,600
Sound ⁵	Type	-		R410A	
	Factory Charge	lbs.		57.5	
	Sound Pressure	dB(A)		67	
	Sound Power	dB(A)		88	

Table 8. 208–230 V heat pump triple modules: 40–44 ton capacity

Model Name		4TVH0480B300NC		4TVH0504B300NC		4TVH0528B300NC				
Individual Models		4TVH0144B300NB + 2x 4TVH0168B300NC		3x 4TVH0168B300NC		2x 4TVH0168B300NC + 4TVH0192B300NC				
Power Supply		208-230/60/3		208-230/60/3		208-230/60/3				
Nominal Tons		40.0		42.0		44.0				
System Type		Ducted		Non-Ducted		Ducted		Non-Ducted		
Performance	Capacity (Nominal) ¹	Cooling	Btu/h	480,000	480,000	504,000	504,000	528,000	528,000	
	Capacity (Rated) ²	Heating	Btu/h	540,000	540,000	567,000	567,000	594,000	594,000	
		Cooling	Btu/h	455,000	455,000	480,000	480,000	500,000	500,000	
		High Temp Heating	Btu/h	510,000	510,000	535,000	535,000	560,000	560,000	
	AHRI -1230 Efficiency Ratings ²	Low Temp Heating	Btu/h	332,000	332,000	348,000	348,000	364,000	364,000	
		EER	-	9.60	9.60	9.60	9.60	9.50	9.50	
		IEER	-	16.60	18.60	16.40	18.40	16.00	18.00	
		COP @ 47°F	-	3.21	3.21	3.21	3.21	3.20	3.20	
	Compressor	Oil	COP @ 17°F	-	2.13	2.23	2.11	2.21	2.10	2.05
			SCHE	-	-	-	-	-	-	
Power		MCA	A	Each individual outdoor unit requires a separate electrical connection. Refer to the electrical data for each individual outdoor unit.						
Compressor	Type (Qty.)	MOP	A	SSC Scroll (6)						
		SCCR	kA	SSC Scroll (6)						
	Model Name	Type	-	SSC Scroll (6)		SSC Scroll (6)		SSC Scroll (6)		
		Initial Charge	fl. oz.	628.8		628.8		628.8		
Oil	Type	-	PVE		PVE		PVE			
	Initial Charge	fl. oz.	628.8		628.8		628.8			

Product Specifications
Table 8. 208–230 V heat pump triple modules: 40–44 ton capacity (continued)

Model Name	4TVH0480B300NC	4TVH0504B300NC	4TVH0528B300NC	
Individual Models	2x 4TVH0144B300NB + 4TVH0168B300NC	3x 4TVH0168B300NC	2x 4TVH0168B300NC + 4TVH0192B300NC	
Power Supply	208-230/60/3			
Nominal Tons	44.0			
System Type	Ducted	Non-Ducted	Ducted	
	Propeller (6)			
Fan	Type (Qty.)	Propeller (6)		
	Output (Each)	W		
	Airflow Rate	CFM		
	External Static Pressure	in. WG		
Piping Connections	Liquid Pipe	dia. in.		
	Gas Pipe	dia. in.		
	High Pressure Gas Pipe (for HR)	dia. in.		
	Installation Limits	Max Length ³	ft	
		Max Height ⁴	ft	
Indoor Unit Connections	Number of connectable Indoor Units			
Refrigerant	Total Capacity (Cooling)	Btu/h		
	Type	-		
Sound ⁵	Factory Charge	lbs.		
	Sound Pressure	dB(A)		
	Sound Power	dB(A)		
External Dimensions	Net Weight	lbs.		
	Shipping Weight	lbs.		
	Net Dimensions (WxHxD)	in.		
	Shipping Dimensions (WxHxD)	in.		

Table 8. 208–230 V heat pump triple modules: 40–44 ton capacity (continued)

Model Name	4TVH0480B300NC	4TVH0504B300NC	4TVH0528B300NC
Individual Models	4TVH0144B300NB + 2x 4TVH0168B300NC	3x 4TVH0168B300NC	2x 4TVH0168B300NC + 4TVH0192B300NC
Power Supply	208-230/60/3	208-230/60/3	208-230/60/3
Nominal Tons	40.0	42.0	44.0
System Type	Ducted	Non-Ducted	Ducted
	Non-Ducted	Ducted	Non-Ducted
Operating Temp Range	Cooling	23 to 120	23 to 120
	Heating	-13 to 75	-13 to 75

Notes:

- Nominal capacity based on 25 ft (7.6 m) of equivalent refrigerant piping with 0 ft level difference.
 - Cooling:** Indoor temperature 80°F DB, 67°F WB/Outdoor temperature 95°F DB, 75°F WB
 - Heating:** Indoor temperature 70°F DB, 60°F WB/Outdoor temperature 47°F DB, 43°F WB
- Rated per AHRI-1230 Standard conditions
- Actual length (equivalent length in parenthesis)
- If the outdoor unit is installed above the indoor unit, the allowable height difference is 361 ft (110 m). If the outdoor unit is installed below the indoor unit, the allowable height difference is 131 ft (40 m).
- Sound pressure was acquired in a dead room. Actual noise level may be different depending on installation conditions.

Table 9. 208-230 V heat recovery single modules: 6-10 ton capacity

Model Name		4TVR0072B300NB		4TVR0096B300NB		4TVR0120B300NB			
Power Supply		208-230/60/3		208-230/60/3		208-230/60/3			
Nominal Tons		6.0		8.0		10.0			
System Type		6.0		8.0		10.0			
		Ducted	Non-Ducted	Ducted	Non-Ducted	Ducted	Non-Ducted		
Performance	Capacity (Nominal) ¹	Cooling	Btu/h	72,000	72,000	96,000	96,000	120,000	120,000
		Heating	Btu/h	81,000	81,000	108,000	108,000	135,000	135,000
	Capacity (Rated) ²	Cooling	Btu/h	69,000	69,000	92,000	92,000	114,000	114,000
		High Temp Heating	Btu/h	77,000	77,000	103,000	103,000	129,000	129,000
	Low Temp Heating	Btu/h	51,000	51,000	67,000	67,000	84,000	84,000	
		EER	-	11.50	14.60	11.60	15.00	11.90	13.10
	AHRI -1230 Efficiency Ratings ²	IEER	-	22.50	33.00	23.00	38.20	23.00	28.70
		COP@ 47°F	-	3.46	4.32	3.60	4.46	3.54	3.97
	COP@ 17°F	-	2.49	2.80	2.47	2.90	2.58	2.62	
		SCHE	-	27.00	29.00	27.50	34.10	26.50	32.00
Power	MCA	A	28	37.8	43.0				
	MOP	A	35	50	50				
	SCCR	kA	5	5	5				
Compressor	TYPE (Qty.)	-	SSC Scroll (1)	SSC Scroll (2)	SSC Scroll (2)				
	MODEL NAME	-	DS-GB052FBVASG	DS-GB052FBVASG x 2	DS-GB052FBVASG x 2				
OIL	Type	-	PVE	PVE	PVE				
	Initial Charge	fl. oz.	131.9	209.6	209.6				
Fan	Type (Qty.)	-	Propeller (1)	Propeller (2)	Propeller (2)				
	Output (Each)	W	630	620	620				
	Airflow Rate	CFM	7,240	9,180	9,180				
	External Static Pressure	in. WG	0.31	0.31	0.31				

Table 9. 208-230 V heat recovery single modules: 6-10 ton capacity (continued)

Model Name	4TVR0072B300NB		4TVR0096B300NB		4TVR0120B300NB	
Power Supply	208-230/60/3		208-230/60/3		208-230/60/3	
Nominal Tons	6.0		8.0		10.0	
System Type	Ducted	Non-Ducted	Ducted	Non-Ducted	Ducted	Non-Ducted
Piping Connections	Liquid Pipe	dia. in.	3/8 Braze	3/8 Braze	1/2 Braze	1/2 Braze
	Gas Pipe	dia. in.	3/4 Braze	7/8 Braze	1-1/8 Braze	1-1/8 Braze
	High Pressure Gas Pipe (for HR)	dia. in.	5/8 Braze	3/4 Braze	7/8 Braze	7/8 Braze
	Installation Limits	Max Length ³	ft	656 (722)	656 (722)	656 (722)
Max Height ⁴		ft	361 (131)	361 (131)	361 (131)	361 (131)
Indoor Unit Connections	Number of Connectable Indoor Units	-	12	16	20	20
Refrigerant	Total Capacity (Cooling)	Btu/h	36,000 – 93,600	48,000 – 124,800	60,000 – 156,000	60,000 – 156,000
	Type	-	R410A	R410A	R410A	R410A
Sound ⁵	Factory Charge	lbs.	12.1	16.3	16.3	16.3
	Sound Pressure	dB(A)	60.0	61.0	61.0	61.0
	Sound Power	dB(A)	77	81	81	81
	Net Weight	lbs.	430	637	637	637
External Dimensions	Shipping Weight	lbs.	465	679	679	679
	Net Dimensions (WxHxD)	in.	34.65 x 66.73 x 30.12	50.98 x 66.73 x 30.12	50.98 x 66.73 x 30.12	50.98 x 66.73 x 30.12
	Shipping Dimensions (WxHxD)	in.	37.32 x 75.28 x 32.76	53.66 x 75.28 x 32.76	53.66 x 75.28 x 32.76	53.66 x 75.28 x 32.76
Operating Temp Range	Cooling ⁶	°F	5 to 120	5 to 120	5 to 120	5 to 120
	Heating	°F	-13 to 75	-13 to 75	-13 to 75	-13 to 75

Table 9. 208–230 V heat recovery single modules: 6–10 ton capacity (continued)

Model Name	4TVR0072B300NB		4TVR0096B300NB		4TVR0120B300NB	
	Ducted	Non-Ducted	Ducted	Non-Ducted	Ducted	Non-Ducted
Power Supply	208–230/60/3		208–230/60/3		208–230/60/3	
Nominal Tons	6.0		8.0		10.0	
System Type	Ducted	Non-Ducted	Ducted	Non-Ducted	Ducted	Non-Ducted

Notes:

- Nominal capacity based on 25 ft (7.6 m) of equivalent refrigerant piping with 0 ft level difference.
 - Cooling:** Indoor temperature 80°F DB, 67°F WB/Outdoor temperature 95°F DB, 75°F WB
 - Heating:** Indoor temperature 70°F DB, 60°F WB/Outdoor temperature 47°F DB, 43°F WB
- Rated per AHRI-1230 Standard conditions
- Actual length (equivalent length in parenthesis)
 - If the outdoor unit is installed above the indoor unit, the allowable height difference is 361 ft (110 m). If the outdoor unit is installed below the indoor unit, the allowable height difference is 131 ft (40 m).
- Sound pressure was acquired in a dead room. Actual noise level may be different depending on installation conditions.
- Cooling operation between 23°F and 5°F requires twin porting of the applicable indoor units.

Table 10. 208-230 V heat recovery single modules: 12-16 ton capacity

Model Name	4TVR0144B300NB		4TVR0168B300NC		4TVR0192B300NC					
Power Supply	208-230/60/3		208-230/60/3		208-230/60/3					
Nominal Tons	12.0		14.0		16.0					
System Type		Ducted	Non-Ducted	Ducted	Non-Ducted	Ducted	Non-Ducted			
		Capacity (Nominal) ¹	Cooling	144,000	144,000	168,000	168,000	192,000	192,000	
Performance	Capacity (Rated) ²	Heating	162,000	162,000	189,000	189,000	216,000	216,000		
		Cooling	138,000	138,000	160,000	160,000	184,000	184,000		
Performance		High Temp Heating	154,000	154,000	180,000	180,000	206,000	206,000		
		Low Temp Heating	100,000	100,000	118,000	118,000	134,000	134,000		
		EER	-	11.70	12.00	10.60	10.60	10.60	10.60	
		IEER	-	21.60	26.50	20.80	24.50	21.00	23.00	
		AHRI-1230 Efficiency Ratings ²	COP @ 47°F	-	3.54	3.81	3.21	3.65	3.20	3.50
		COP @ 17°F	-	2.42	2.55	2.25	2.50	2.20	2.45	
		SCHE	-	26.00	27.50	25.00	26.50	23.50	26.00	
Power	MCA	A	52.6		66.0	73.0A				
	MOP	A	70		80	90				
	SCCR	kA	5		5	5				
Compressor	TYPE (Qty.)	-	SSC Scroll (2)		SSC Scroll (2)	SSC Scroll (2)				
	MODEL NAME	-	DS-GB052FBVASG x 2		DS-GB052FAVBSG	DS4G15066EVASG				
	Type	-	PVE		PVE	PVE				
	OIL Initial Charge	fl. oz.	209.6		209.6	209.6				
Fan	Type (Qty.)	-	Propeller (2)		Propeller (2)	Propeller (2)				
	Output (Each)	W	620		620	620				
	Airflow Rate	CFM	9,535		10,950	10,950				
	External Static Pressure	in. WG	0.31		0.31	0.31				

Product Specifications
Table 10. 208-230 V heat recovery single modules: 12-16 ton capacity (continued)

Model Name	4TVR0144B300NB		4TVR0168B300NC		4TVR0192B300NC	
Power Supply	208-230/60/3		208-230/60/3		208-230/60/3	
Nominal Tons	12.0		14.0		16.0	
System Type	Ducted	Non-Ducted	Ducted	Non-Ducted	Ducted	Non-Ducted
Piping Connections	Liquid Pipe	dia. in.	1/2 Braze	5/8 Braze	5/8 Braze	5/8 Braze
	Gas Pipe	dia. in.	1-1/8 Braze	1-1/8 Braze	1-1/8 Braze	1-1/8 Braze
	High Pressure Gas Pipe (for HR)	dia. in.	7/8 Braze	7/8 Braze	7/8 Braze	1-1/8 Braze
	Installation Limits	Max Length ³	ft	656 (722)	656 (722)	656 (722)
Max Height ⁴		ft	361 (131)	361 (131)	361 (131)	361 (131)
Indoor Unit Connections	Number of Connectable Indoor Units	-	25	29	33	33
	Total Capacity (Cooling)	Btu/h	72,000 – 187,200	84,000 – 218,400	96,000 – 249,600	96,000 – 249,600
Refrigerant	Type	-	R410A	R410A	R410A	R410A
	Factory Charge	lbs.	19.2	24.3	24.3	24.3
Sound ⁵	Sound Pressure	dB(A)	62.0	63.0	64.0	64.0
	Sound Power	dB(A)	83	85	86	86
	Net Weight	lbs.	672	732	750	750
	Shipping Weight	lbs.	714	770	788	788
External Dimensions	Net Dimensions (WxHxD)	in.	50.98 x 66.73 x 30.12	50.98 x 66.73 x 30.12	50.98 x 66.73 x 30.12	50.98 x 66.73 x 30.12
	Shipping Dimensions (WxHxD)	in.	53.66 x 75.28 x 32.76	53.66 x 75.28 x 32.76	53.66 x 75.28 x 32.76	53.66 x 75.28 x 32.76
Operating Temp Range	Cooling ⁶	°F	5 to 120	5 to 120	5 to 120	5 to 120
	Heating	°F	-13 to 75	-13 to 75	-13 to 75	-13 to 75

Table 10. 208–230 V heat recovery single modules: 12–16 ton capacity (continued)

Model Name	4TVR0144B300NB	4TVR0168B300NC	4TVR0192B300NC
Power Supply	208–230/60/3	208–230/60/3	208–230/60/3
Nominal Tons	12.0	14.0	16.0
System Type	Ducted Non-Ducted	Ducted Non-Ducted	Ducted Non-Ducted

Notes:

1. Nominal capacity based on 25 ft (7.6 m) of equivalent refrigerant piping with 0 ft level difference.
 - **Cooling:** Indoor temperature 80°F DB, 67°F WB/Outdoor temperature 95°F DB, 75°F WB
 - **Heating:** Indoor temperature 70°F DB, 60°F WB/Outdoor temperature 47°F DB, 43°F WB
2. Rated per AHRI-1230 Standard conditions
3. Actual length (equivalent length in parenthesis)
4. If the outdoor unit is installed above the indoor unit, the allowable height difference is 361 ft (110 m). If the outdoor unit is installed below the indoor unit, the allowable height difference is 131 ft (40 m).
5. Sound pressure was acquired in a dead room. Actual noise level may be different depending on installation conditions.
6. Cooling operation between 23°F and 5°F requires twin porting of the applicable indoor units.

Product Specifications
Table 11. 208–230 V heat recovery dual modules: 18–24 ton capacity

Model Name		4TVR0216B300NC		4TVR0240B300NC		4TVR0264B300NC		4TVR0288B300NC	
Individual Models		4TVR0072B300NB + 4TVR0144B300NB		4TVR0072B300NB + 4TVR0168B300NC		4TVR0072B300NB + 4TVR0192B300NC		2x 4TVH0144B300NB	
Power Supply		208–230/60/3		208–230/60/3		208–230/60/3		208–230/60/3	
Nominal Tons		18.0		20.0		22.0		24.0	
System Type	Capacity (Nominal) ¹	Ducted		Non-Ducted		Ducted		Non-Ducted	
		Btu/h	Btu/h	Btu/h	Btu/h	Btu/h	Btu/h	Btu/h	Btu/h
Performance	Capacity (Rated) ²	Cooling	216,000	240,000	240,000	264,000	264,000	288,000	288,000
		Heating	243,000	270,000	270,000	297,000	297,000	324,000	324,000
	Cooling	206,000	228,000	228,000	252,000	252,000	276,000	276,000	
	High Temp Heating	230,000	258,000	258,000	282,000	282,000	308,000	308,000	
	Low Temp Heating	150,000	168,000	168,000	184,000	184,000	200,000	200,000	
	EER	-	10.60	10.60	10.60	10.10	10.10	10.00	12.00
	IEER	-	20.50	20.10	22.00	19.60	21.90	21.60	22.00
	AHRI -1.230 Efficiency Ratings ²	COP@ 47°F	3.34	3.20	3.51	3.20	3.35	3.32	3.58
	COP@ 17°F	-	2.31	2.40	2.38	2.17	2.31	2.36	2.48
	SCHE	-	20.50	20.50	23.50	20.50	23.50	21.50	23.50
Power	MCA	A		A		A		A	
	MOP	A		A		A		A	
	SCCR	kA		kA		kA		kA	
Compressor	Type (Qty.)	SSC Scroll (3)		SSC Scroll (3)		SSC Scroll (3)		SSC Scroll (4)	
	Model Name	DS-GB052FBVAVSG x 3		DS-GB052FBVAVSG x 3		DS-GB052FBVAVSG x 1 + DS4GJ5066EVAVSG X 2		DS-GB052FBVAVSG x 4	
	Oil	Type	PVE	PVE	PVE	PVE	PVE	PVE	PVE
	Initial Charge	341.5		341.5		341.5		419.2	

Each individual outdoor unit requires a separate electrical connection. Refer to the electrical data for each individual outdoor unit.

Table 11. 208–230 V heat recovery dual modules: 18–24 ton capacity (continued)

Model Name	4TVR0216B300NC	4TVR0240B300NC	4TVR0264B300NC	4TVR0288B300NC
Individual Models	4TVR0072B300NB + 4TVR0144B300NB	4TVR0072B300NB + 4TVR0168B300NC	4TVR0072B300NB + 4TVR0192B300NC	2x 4TVH0144B300NB
Power Supply	208–230/60/3			
Nominal Tons	18.0		22.0	
System Type	Ducted	Non-Ducted	Ducted	Non-Ducted
Type (Qty.)	Propeller (3)			
Output (Each)	630 + (620 x 2)			
Airflow Rate	7,240 + 9,535			
External Static Pressure	0.31			
Liquid Pipe	5/8 Braze			
Gas Pipe	1-1/8 Braze			
High Pressure Gas Pipe (for HR)	1-1/8 Braze			
Installation Limits	Max Length ³	656 (722)		
	Max Height ⁴	361 (131)		
Number of Connectable Indoor Units	37			
Total Capacity (Cooling)	108,000 – 280,800			
Type	R410A			
Factory Charge	31.3			
Sound Pressure	64			
Sound Power	84			
Fan	Type (Qty.)	Propeller (3)		
	Output (Each)	630 + (620 x 2)		
Piping Connections	Liquid Pipe	5/8 Braze		
	Gas Pipe	1-1/8 Braze		
Indoor Unit Connections	Number of Connectable Indoor Units	41		
	Total Capacity (Cooling)	120,000 – 312,000		
Refrigerant	Type	R410A		
	Factory Charge	36.4		
Sound ⁵	Sound Pressure	65		
	Sound Power	86		

Table 11. 208–230 V heat recovery dual modules: 18–24 ton capacity (continued)

Model Name	4TVR0216B300NC		4TVR0240B300NC		4TVR0264B300NC		4TVR0288B300NC	
	4TVR0072B300NB + 4TVR0144B300NB		4TVR0072B300NB + 4TVR0168B300NC		4TVR0072B300NB + 4TVR0192B300NC		2x 4TVH0144B300NB	
Power Supply	208–230/60/3		208–230/60/3		208–230/60/3		208–230/60/3	
Nominal Tons	18.0		20.0		22.0		24.0	
System Type	Ducted	Non-Ducted	Ducted	Non-Ducted	Ducted	Non-Ducted	Ducted	Non-Ducted
	External Dimensions	Net Weight	lbs.	430 + 672	430 + 732	430 + 750	672 x 2	
Shipping Weight		lbs.	465 + 714	465 + 770	465 + 788	714 x 2		
Net Dimensions (WxHxD)		in.	34.65 x 66.73 x 30.12 + 50.98 x 6.73 x 30.12	34.65 x 66.73 x 0.12 + 50.98 x 66.73 x 30.12	34.65 x 66.73 x 30.12 + 50.98 x 66.73 x 30.12	(50.98 x 66.73 x 30.12) x 2		
Operating Temp Range	Shipping Dimensions (WxHxD)	in.	37.32 x 75.28 x 2.76 + 53.66 x 75.28 x 32.76	37.32 x 75.28 x 32.76 + 53.66 x 75.28 x 32.76	37.32 x 75.28 x 32.76 + 53.66 x 75.28 x 32.76	(53.66 x 75.28 x 32.76) x 2		
	Cooling ⁶	°F	5 to 120	5 to 120	5 to 120	5 to 120		
	Heating	°F	-13 to 75	-13 to 75	-13 to 75	-13 to 75		

Notes:

- Nominal capacity based on 25 ft (7.6 m) of equivalent refrigerant piping with 0 ft level difference.
 - Cooling:** Indoor temperature 80°F DB, 67°F WB/Outdoor temperature 95°F DB, 75°F WB
 - Heating:** Indoor temperature 70°F DB, 60°F WB/Outdoor temperature 47°F DB, 43°F WB
- Rated per AHRI-1230 Standard conditions
- Actual length (equivalent length in parenthesis)
- If the outdoor unit is installed above the indoor unit, the allowable height difference is 361 ft (110 m). If the outdoor unit is installed below the indoor unit, the allowable height difference is 131 ft (40 m).
- Sound pressure was acquired in a dead room. Actual noise level may be different depending on installation conditions.
- Cooling operation between 23°F and 5°F requires twin porting of the applicable indoor units.

Table 12. 208–230 V heat recovery dual modules: 26–32 ton capacity

Model Name		4TVH0312B300NC		4TVR0336B300NC		4TVR0360B300NC		4TVR0384B300NC	
Individual Models		4TVR0144B300NB + 4TVR0168B300NC		2x 4TVR0168B300NC		4TVR0168B300NC + 4TVR0192B300NC		2x 4TVR0192B300NC	
Power Supply		208–230/60/3		208–230/60/3		208–230/60/3		208–230/60/3	
Nominal Tons		26.0		28.0		30.0		32.0	
System Type		Ducted	Non-Ducted	Ducted	Non-Ducted	Ducted	Non-Ducted	Ducted	Non-Ducted
		Capacity (Nominal) ¹	Cooling	312,000	312,000	336,000	336,000	360,000	288,000
Capacity (Rated) ²	Heating	351,000	351,000	378,000	378,000	405,000	405,000	432,000	432,000
	Cooling	298,000	298,000	320,000	320,000	344,000	344,000	366,000	366,000
Performance	High Temp Heating	334,000	334,000	360,000	360,000	386,000	386,000	410,000	410,000
	Low Temp Heating	218,000	218,000	234,000	234,000	250,000	250,000	268,000	268,000
AHRI -1230 Efficiency Ratings ²	EER	-	9.90	9.80	9.80	9.70	9.70	9.70	9.70
	IEER	-	20.10	19.40	19.40	18.90	20.00	18.50	19.50
	COP@ 47°F	-	3.20	3.20	3.20	3.20	3.20	3.20	3.20
	COP@ 17°F	-	2.41	2.46	2.38	2.43	2.38	2.42	2.41
	SCHE	-	20.50	23.50	20.50	23.10	19.70	22.40	19.00
MCA		A							
MOP		A							
SCCR		kA							
Type (Qty.)		-	SSC Scroll (4)	SSC Scroll (4)	SSC Scroll (4)	SSC Scroll (4)	SSC Scroll (4)	SSC Scroll (4)	SSC Scroll (4)
Model Name		-	DS-GB052FBVAVSG x 4	DS-GB052FBVAVSG x 4	DS-GB052FBVAVSG x 4	DS-GB052FBVAVSG x 2 + DS4GJ5066EVAVSG X 2	DS-GB052FBVAVSG x 2 + DS4GJ5066EVAVSG X 2	DS4GJ5066EVAVSG X 4	
Oil	Type	-	PVE	PVE	PVE	PVE	PVE	PVE	PVE
	Initial Charge	fl. oz.	419.2	419.2	419.2	419.2	419.2	419.2	419.2

Each individual outdoor unit requires a separate electrical connection. Refer to the electrical data for each individual outdoor unit.



Product Specifications

Table 12. 208–230 V heat recovery dual modules: 26–32 ton capacity (continued)

Model Name	4TVH0312B300NC	4TVR0336B300NC	4TVR0360B300NC	4TVR0384B300NC
Individual Models	4TVR0144B300NB + 4TVR0168B300NC	2x 4TVR0168B300NC	4TVR0168B300NC + 4TVR0192B300NC	2x 4TVR0192B300NC
Power Supply	208–230/60/3	208–230/60/3	208–230/60/3	208–230/60/3
Nominal Tons	26.0	28.0	30.0	32.0
System Type	Ducted	Ducted	Ducted	Ducted
	Non-Ducted	Non-Ducted	Non-Ducted	Non-Ducted
Type (Qty.)	-	Propeller (4)	Propeller (4)	Propeller (4)
Output (Each)	W	(620 x 2) + (620 X 2)	(620 x 2) + (620 X 2)	(620 x 2) + (620 X 2)
Airflow Rate	CFM	9,535 + 10,950	10,950 x 2	10,950 x 2
External Static Pressure	in. WG	0.31	0.31	0.31
Liquid Pipe	dia. in.	3/4 Braze	3/4 Braze	3/4 Braze
Gas Pipe	dia. in.	1-3/8 Braze	1-3/8 Braze	1-5/8 Braze
High Pressure Gas Pipe (for HR)	dia. in.	1-1/8 Braze	1-1/8 Braze	1-3/8 Braze
Installation Limits	Max Length ³	ft	656 (722)	656 (722)
	Max Height ⁴	ft	361 (131)	361 (131)
Number of Connectable Indoor Units	-	54	58	64
Total Capacity (Cooling)	Btu/h	156,000 – 405,600	168,000 – 436,800	180,000 – 468,000
Type	-	R410A	R410A	R410A
Factory Charge	lbs.	43.4	48.5	48.5
Sound Pressure	dB(A)	66	66	66
Sound Power	dB(A)	97	88	88

Table 12. 208–230 V heat recovery dual modules: 26–32 ton capacity (continued)

Model Name	4TVH0312B300NC	4TVR0336B300NC	4TVR0360B300NC	4TVR0384B300NC
Individual Models	4TVR0144B300NB + 4TVR0168B300NC	2x 4TVR0168B300NC	4TVR0168B300NC + 4TVR0192B300NC	2x 4TVR0192B300NC
Power Supply	208–230/60/3	208–230/60/3	208–230/60/3	208–230/60/3
Nominal Tons	26.0	28.0	30.0	32.0
System Type	Ducted	Non-Ducted	Ducted	Non-Ducted
External Dimensions	Net Weight	lbs.	732 x 2	750 x 2
	Shipping Weight	lbs.	770 x 2	788 x 2
	Net Dimensions (WxHxD)	in.	(50.98 x 66.73 x 30.12) x 2	(50.98 x 66.73 x 30.12) x 2
Operating Temp Range	Shipping Dimensions (WxHxD)	in.	(53.66 x 75.28 x 32.76) x 2	(53.66 x 75.28 x 32.76) x 2
	Cooling ⁶	°F	5 to 120	5 to 120
	Heating	°F	-13 to 75	-13 to 75

Notes:

- Nominal capacity based on 25 ft (7.6 m) of equivalent refrigerant piping with 0 ft level difference.
 - Cooling:** Indoor temperature 80°F DB, 67°F WB/Outdoor temperature 95°F DB, 75°F WB
 - Heating:** Indoor temperature 70°F DB, 60°F WB/Outdoor temperature 47°F DB, 43°F WB
- Rated per AHRI-1230 Standard conditions
- Actual length (equivalent length in parenthesis)
- If the outdoor unit is installed above the indoor unit, the allowable height difference is 361 ft (110 m). If the outdoor unit is installed below the indoor unit, the allowable height difference is 131 ft (40 m).
- Sound pressure was acquired in a dead room. Actual noise level may be different depending on installation conditions.
- Cooling operation between 23°F and 5°F requires twin porting of the applicable indoor units.

Product Specifications
Table 13. 208–230 V heat recovery triple module: 34–38 ton capacity

Model Name		4TVR0408B300NC		4TVR0432B300NC		4TVR0456B300NC			
Individual Models		4TVR0072B300NB + 4TVR0144B300NB + 4TVR0192B300NC		3x 4TVR0144B300NB		4TVR0120B300NB + 2x 4TVR0168B300NC			
Power Supply		208–230/60/3		208–230/60/3		208–230/60/3			
Nominal Tons		34.0		36.0		38.0			
System Type		Ducted		Non-Ducted		Ducted		Non-Ducted	
		Capacity (Nominal) ¹	Cooling	Btu/h	408,000	408,000	432,000	432,000	456,000
Capacity (Rated) ²	Heating	Btu/h	459,000	459,000	486,000	486,000	513,000	513,000	
	Cooling	Btu/h	390,000	390,000	415,000	415,000	435,000	435,000	
Performance	High Temp Heating	Btu/h	435,000	435,000	460,000	460,000	490,000	490,000	
	Low Temp Heating	Btu/h	284,000	284,000	300,000	300,000	320,000	320,000	
AHRI -1230 Efficiency Ratings ²	EER	-	9.80	9.80	9.60	9.60	9.70	9.70	
	IEER	-	17.80	19.10	17.00	19.10	16.50	19.00	
	COP @ 47°F	-	3.20	3.20	3.20	3.20	3.22	3.23	
	COP @ 17°F	-	2.36	2.36	2.28	2.33	2.17	2.27	
Power	SCHE	-	19.00	22.00	17.00	21.50	19.00	21.50	
	MCA	A							
	MOP	A							
Compressor	SCCR	kA							
	Type (Qty.)	-	SSC Scroll (5)		SSC Scroll (6)		SSC Scroll (6)		
Oil	Model Name	-	DS-GB052FBVAVAG x 3 + DS4GJ5066EVAAG x 2		DS-GB052FBVAVAG x 6		DS-GB052FBVAVAG x 6		
	Type	-	PVE		PVE		PVE		
	Initial Charge	fl. oz.	551.1		628.8		628.8		

Each individual outdoor unit requires a separate electrical connection. Refer to the electrical data for each individual outdoor unit.

Table 13. 208-230 V heat recovery triple module: 34-38 ton capacity (continued)

Model Name		4TVR0408B300NC	4TVR0432B300NC	4TVR0456B300NC	
Individual Models		4TVR0072B300NB + 4TVR0144B300NB + 4TVR0192B300NC	3x 4TVR0144B300NB	4TVR0120B300NB + 2x 4TVR0168B300NC	
Power Supply		208-230/60/3			
Nominal Tons		34.0			
System Type		36.0			
Fan	Type (Qty.)	Propeller (5)			
	Output (Each)	Propeller (6)			
Piping Connections	Airflow Rate	CFM	630 + (620 x 2) + (620 X 2)	(620 x 2) + (620 x 2) + (620 X 2)	
	External Static Pressure	in. WG	7,240 + 9,535 + 10,950	9,535 X 3	
	Liquid Pipe	dia. in.	0.31	0.31	
	Gas Pipe	dia. in.	3/4 Braze	3/4 Braze	
	High Pressure Gas Pipe (for HR)			1-5/8 Braze	1-5/8 Braze
				1-3/8 Braze	1-3/8 Braze
	Installation Limits	Max Length ³	ft	656 (722)	656 (722)
		Max Height ⁴	ft	361 (131)	361 (131)
	Number of Connectable Indoor Units			64	64
	Total Capacity (Cooling)	Btu/h		216,000 - 561,600	228,000 - 592,800
Refrigerant	Type		R410A	R410A	
Sound ⁵	Factory Charge	lbs.	55.6	64.8	
	Sound Pressure	dB(A)	67	67	
	Sound Power	dB(A)	88	89	
External Dimensions	Net Weight	lbs.	430 + 672 + 750	637 + (732 x 2)	
	Shipping Weight	lbs.	465 + 714 + 788	679 + (770 x 2)	
	Net Dimensions (WxHxD)	in.	34.65 x 66.73 x 30.12 + (50.98 x 66.73 x 30.12) x2	(50.98 x 66.73 x 30.12) x 3	
	Shipping Dimensions (WxHxD)	in.	37.32 x 75.28 x 32.76 + (53.66 x 75.28 x 32.76) x2	(53.66 x 75.28 x 32.76) x 3	

Table 13. 208–230 V heat recovery triple module: 34–38 ton capacity (continued)

Model Name		4TVR0408B300NC	4TVR0432B300NC	4TVR0456B300NC			
Individual Models		4TVR0072B300NB + 4TVR0144B300NB + 4TVR0192B300NC	3x 4TVR0144B300NB	4TVR0120B300NB + 2x 4TVR0168B300NC			
Power Supply		208–230/60/3					
Nominal Tons		38.0					
System Type	Operating Temp Range	34.0		36.0		38.0	
		Ducted	Non-Ducted	Ducted	Non-Ducted	Ducted	Non-Ducted
	Cooling ⁶	5 to 120		5 to 120		5 to 120	
	Heating	-13 to 75		-13 to 75		-13 to 75	

Notes:

- Nominal capacity based on 25 ft (7.6 m) of equivalent refrigerant piping with 0 ft level difference.
 - Cooling:** Indoor temperature 80°F DB, 67°F WB/Outdoor temperature 95°F DB, 75°F WB
 - Heating:** Indoor temperature 70°F DB, 60°F WB/Outdoor temperature 47°F DB, 43°F WB
- Rated per AHRI-1230 Standard conditions
- Actual length (equivalent length in parenthesis)
- If the outdoor unit is installed above the indoor unit, the allowable height difference is 361 ft (110 m). If the outdoor unit is installed below the indoor unit, the allowable height difference is 131 ft (40 m).
- Sound pressure was acquired in a dead room. Actual noise level may be different depending on installation conditions.
- Cooling operation between 23°F and 5°F requires twin porting of the applicable indoor units.

Table 14. 208–230 V heat recovery triple module: 40–54 ton capacity

Model Name		4TVR0480B300NC		4TVR0504B300NC		4TVR0528B300NC		
Individual Models		4TVR0144B300NB + 2x 4TVR0168B300NC		3x 4TVR0168B300NC		2x 4TVR0168B300NC + 4TVR0192B300NC		
Power Supply		208–230/60/3		208–230/60/3		208–230/60/3		
Nominal Tons		44.0		42.0		44.0		
System Type		44.0		42.0		44.0		
		Ducted	Non-Ducted	Ducted	Non-Ducted	Ducted	Non-Ducted	
Performance	Capacity (Nominal) ¹	Cooling	Btu/h	480,000	480,000	504,000	504,000	
		Heating	Btu/h	540,000	540,000	567,000	594,000	
	Capacity (Rated) ²	Cooling	Btu/h	455,000	455,000	480,000	500,000	
		High Temp Heating	Btu/h	510,000	510,000	535,000	560,000	
		Low Temp Heating	Btu/h	332,000	332,000	348,000	364,000	
	AHRI - 1230 Efficiency Ratings ²	EER	-	9.60	9.60	9.60	9.50	9.50
		IEER	-	16.60	18.60	16.40	18.40	18.00
		COP @ 47°F	-	3.21	3.21	3.21	3.21	3.20
		COP @ 17°F	-	2.13	2.23	2.11	2.21	2.05
		SCHE	-	19.00	21.50	19.00	20.00	19.00
Power	MCA	A						
	MOP	A						
	SCCR	kA						
Compressor	Type (Qty.)	-		SSC Scroll (6)		SSC Scroll (6)		
	Model Name	-		DS-GB052FBVASG x 6		DS-GB052FBVASG x 4 + DS4GJ5066EVASG x 2		
	Oil	Type	-		PVE		PVE	
		Initial Charge	-		628.8		628.8	

Each individual outdoor unit requires a separate electrical connection. Refer to the electrical data for each individual outdoor unit.

Product Specifications
Table 14. 208–230 V heat recovery triple module: 40–54 ton capacity (continued)

Model Name		4TVR0480B300NC		4TVR0504B300NC		4TVR0528B300NC			
Individual Models		4TVR0144B300NB + 2x 4TVR0168B300NC		3x 4TVR0168B300NC		2x 4TVR0168B300NC + 4TVR0192B300NC			
Power Supply		208–230/60/3		208–230/60/3		208–230/60/3			
Nominal Tons		40.0		42.0		44.0			
System Type		Ducted		Non-Ducted		Ducted		Non-Ducted	
Fan	Type (Qty.)	-		Propeller (6)		Propeller (6)		Propeller (6)	
	Output (Each)	W		(620 x 2) + (620 x 2) + (620 x 2)		(620 x 2) + (620 x 2) + (620 x 2)		(620 x 2) + (620 x 2) + (620 x 2)	
	Airflow Rate	CFM		9,535 + (10,950 x 2)		10,950 x 3		10,950 x 3	
	External Static Pressure	in. WG		0.31		0.31		0.31	
Piping Connections	Liquid Pipe	dia. in.		3/4 Braze		3/4 Braze		3/4 Braze	
	Gas Pipe	dia. in.		1-5/8 Braze		1-5/8 Braze		1-5/8 Braze	
	High Pressure Gas Pipe (for HR)	Ø in.		1-3/8 Braze		1-3/8 Braze		1-3/8 Braze	
	Installation Limits	Max Length ³	ft		656 (722)		656 (722)		656 (722)
Max Height ⁴		ft		361 (131)		361 (131)		361 (131)	
Indoor Unit Connections	Number of Connectable Indoor Units	-		64		64		64	
	Total Capacity (Cooling)	Btu/h		240,000 – 624,000		252,000 – 655,200		264,000 – 686,400	
Refrigerant	Type	-		R410A		R410A		R410A	
	Factory Charge	lbs.		67.7		72.8		72.8	
Sound ⁵	Sound Pressure	dB(A)		67		68		68	
	Sound Power	dB(A)		89		90		90	
	Net Weight	lbs.		672 + (732 x 2)		732 x 3		(732 x 2) + 750	
External Dimensions	Shipping Weight	lbs.		714 + (770 x 2)		770 x 3		(770 x 2) + 788	
	Net Dimensions (WxHxD)	in.		(50.98 x 66.73 x 30.12) x 3		(50.98 x 66.73 x 30.12) x 3		(50.98 x 66.73 x 30.12) x 3	
	Shipping Dimensions (WxHxD)	in.		(53.66 x 75.28 x 32.76) x 3		(53.66 x 75.28 x 32.76) x 3		(53.66 x 75.28 x 32.76) x 3	

Table 14. 208–230 V heat recovery triple module: 40–54 ton capacity (continued)

Model Name	4TVR0480B300NC	4TVR0504B300NC	4TVR0528B300NC
Individual Models	4TVR0144B300NB + 2x 4TVR0168B300NC	3x 4TVR0168B300NC	2x 4TVR0168B300NC + 4TVR0192B300NC
Power Supply	208–230/60/3	208–230/60/3	208–230/60/3
Nominal Tons	40.0	42.0	44.0
System Type	Ducted	Ducted	Ducted
	Non-Ducted	Non-Ducted	Non-Ducted
Operating Temp Range	Cooling ⁶	5 to 120	5 to 120
	Heating	°F -13 to 75	°F -13 to 75

Notes:

- Nominal capacity based on 25 ft (7.6 m) of equivalent refrigerant piping with 0 ft level difference.
 - Cooling:** Indoor temperature 80°F DB, 67°F WB/Outdoor temperature 95°F DB, 75°F WB
 - Heating:** Indoor temperature 70°F DB, 60°F WB/Outdoor temperature 47°F DB, 43°F WB
- Rated per AHRI-1230 Standard conditions
- Actual length (equivalent length in parenthesis)
- If the outdoor unit is installed above the indoor unit, the allowable height difference is 361 ft (110 m). If the outdoor unit is installed below the indoor unit, the allowable height difference is 131 ft (40 m).
- Sound pressure was acquired in a dead room. Actual noise level may be different depending on installation conditions.
- Cooling operation between 23°F and 5°F requires twin porting of the applicable indoor units.

Table 15. 460 V heat pump single module: 6–10 ton capacity (continued)

Model Name	4TVH0072B400NB		4TVH0096B400NB		4TVH0120B400NB	
Power Supply	460/60/3		460/60/3		460/60/3	
Nominal Tons	6.0		8.0		10.0	
System Type	Ducted	Non-Ducted	Ducted	Non-Ducted	Ducted	Non-Ducted
Piping Connections	Liquid Pipe	dia. in.	3/8 Braze	3/8 Braze	1/2 Braze	
	Gas Pipe	dia. in.	3/4 Braze	7/8 Braze	1-1/8 Braze	
	High Pressure Gas Pipe (for HR)	dia. in.	N/A	N/A	N/A	
	Installation Limits	Max Length ³	ft	656 (722)	656 (722)	656 (722)
Max Height ⁴		ft	361 (131)	361 (131)	361 (131)	
Indoor Unit Connections	Number of Connectable Indoor Units	-	12	16	20	
Refrigerant	Total Capacity (Cooling)	Btu/h	36,000 – 93,600	48,000 – 124,800	60,000 – 156,000	
	Type	-	R410A	R410A	R410A	
Sound ⁵	Factory Charge	lbs.	12.1	16.3	16.3	
	Sound Pressure	dB(A)	60.0	61.0	61.0	
	Sound Power	dB(A)	77	81	81	
External Dimensions	Net Weight	lbs.	437	540	540	
	Shipping Weight	lbs.	472	582	582	
	Net Dimensions (WxHxD)	in.	34.65 x 66.73 x 30.12	50.98 x 66.73 x 30.12	50.98 x 66.73 x 30.12	
Operating Temp Range	Shipping Dimensions (WxHxD)	in.	37.32 x 75.28 x 32.76	53.66 x 75.28 x 32.76	53.66 x 75.28 x 32.76	
	Cooling	°F	23 to 120	23 to 120	23 to 120	
	Heating	°F	-13 to 75	-13 to 75	-13 to 75	

Table 15. 460 V heat pump single module: 6–10 ton capacity (continued)

Model Name	4TVH0072B400NB		4TVH0096B400NB		4TVH0120B400NB	
	Ducted	Non-Ducted	Ducted	Non-Ducted	Ducted	Non-Ducted
Power Supply	460/60/3		460/60/3		460/60/3	
Nominal Tons	6.0		8.0		10.0	
System Type	Ducted	Non-Ducted	Ducted	Non-Ducted	Ducted	Non-Ducted

Notes:

1. Nominal capacity based on 25 ft (7.6 m) of equivalent refrigerant piping with 0 ft level difference.
 - **Cooling:** Indoor temperature 80°F DB, 67°F WB/Outdoor temperature 95°F DB, 75°F WB
 - **Heating:** Indoor temperature 70°F DB, 60°F WB/Outdoor temperature 47°F DB, 43°F WB
2. Rated per AHRI-1230 Standard conditions
3. Actual length (equivalent length in parenthesis)
4. If the outdoor unit is installed above the indoor unit, the allowable height difference is 361 ft (110 m). If the outdoor unit is installed below the indoor unit, the allowable height difference is 131 ft (40 m).
5. Sound pressure was acquired in a dead room. Actual noise level may be different depending on installation conditions.

Table 16. 460 V heat pump single module: 12–16 ton capacity

Model Name		4TVH0144B400NB		4TVH0168B400NC		4TVH0192B400NC	
Power Supply		460/60/3		460/60/3		460/60/3	
Nominal Tons		12.0		14.0		16.0	
System Type		Ducted	Non-Ducted	Ducted	Non-Ducted	Ducted	Non-Ducted
		Capacity (Nominal) ¹	Btu/h	144,000	144,000	168,000	168,000
	Heating	162,000	162,000	189,000	189,000	216,000	216,000
	Cooling	138,000	138,000	160,000	160,000	184,000	184,000
Performance	High Temp Heating	154,000	154,000	180,000	180,000	206,000	206,000
	Low Temp Heating	100,000	100,000	118,000	118,000	134,000	134,000
AHRI -1230 Efficiency Ratings ²	EER	-	11.70	10.60	10.90	10.60	10.60
	IEER	-	21.60	20.80	24.50	21.00	23.00
	COP @ 47°F	-	3.54	3.21	3.65	3.20	3.50
	COP @ 17°F	-	2.42	2.25	2.50	2.20	2.45
	SCHE	-	-	-	-	-	-
Power	MCA	A	28.7	33.0		37.0	
	MOP	A	40	40		50	
	SCCR	kA	5	5		5	
Compressor	Type (Qty.)	-	SSC Scroll (2)	SSC Scroll (2)		SSC Scroll (2)	
	Model Name	-	DS-GB052FAVBSSG	DS-GB052FAVBSSG		DS-GB066FAVBSSG	
Oil	Type	-	PVE	PVE		PVE	
	Initial Charge	fl. oz.	209.6	209.6		209.6	
Fan	Type (Qty.)	-	Propeller (2)	Propeller (2)		Propeller (2)	
	Output (Each)	W	620	620		620	
	Airflow Rate	CFM	9,535	10,950		10,950	
	External Static Pressure	in. WG	0.31	0.31		0.31	

Product Specifications
Table 16. 460 V heat pump single module: 12–16 ton capacity (continued)

Model Name		4TVH0144B400NB		4TVH0168B400NC		4TVH0192B400NC	
Power Supply		460/60/3		460/60/3		460/60/3	
Nominal Tons		12.0		14.0		16.0	
System Type		Ducted	Non-Ducted	Ducted	Non-Ducted	Ducted	Non-Ducted
Piping Connections	Liquid Pipe	1/2 Braze		5/8 Braze		5/8 Braze	
	Gas Pipe	1-1/8 Braze		1-1/8 Braze		1-1/8 Braze	
	High Pressure Gas Pipe (for HR)	N/A		N/A		N/A	
	Installation Limits	Max Length ³	656 (722)	656 (722)	656 (722)	656 (722)	656 (722)
	Max Height ⁴	361 (131)	361 (131)	361 (131)	361 (131)	361 (131)	361 (131)
Indoor Unit Connections	Number of Connectable Indoor Units	25		29		33	
	Total Capacity (Cooling)	72,000 – 187,200		84,000 – 218,400		96,000 – 249,600	
Refrigerant	Type	R410A		R410A		R410A	
	Factory Charge	19.2		24.3		24.3	
Sound ⁵	Sound Pressure	62.0		63.0		64.0	
	Sound Power	83		85		86	
	Net Weight	672		719		737	
	Shipping Weight	714		757		774	
External Dimensions	Net Dimensions (WxHxD)	50.98 x 66.73 x 30.12		50.98 x 66.73 x 30.12		50.98 x 66.73 x 30.12	
	Shipping Dimensions (WxHxD)	53.66 x 75.28 x 32.76		53.66 x 75.28 x 32.76		53.66 x 75.28 x 32.76	
Operating Temp Range	Cooling	23 to 120		23 to 120		23 to 120	
	Heating	-13 to 75		-13 to 75		-13 to 75	

Table 16. 460 V heat pump single module: 12–16 ton capacity (continued)

Model Name	4TVH0144B400NB	4TVH0168B400NC	4TVH0192B400NC
Power Supply	460/60/3	460/60/3	460/60/3
Nominal Tons	12.0	14.0	16.0
System Type	Ducted	Ducted	Ducted
	Non-Ducted	Non-Ducted	Non-Ducted

Notes:

- Nominal capacity based on 25 ft (7.6 m) of equivalent refrigerant piping with 0 ft level difference.
 - Cooling:** Indoor temperature 80°F DB, 67°F WB/Outdoor temperature 95°F DB, 75°F WB
 - Heating:** Indoor temperature 70°F DB, 60°F WB/Outdoor temperature 47°F DB, 43°F WB
- Rated per AHRI-1230 Standard conditions
- Actual length (equivalent length in parenthesis)
- If the outdoor unit is installed above the indoor unit, the allowable height difference is 361 ft (110 m). If the outdoor unit is installed below the indoor unit, the allowable height difference is 131 ft (40 m).
- Sound pressure was acquired in a dead room. Actual noise level may be different depending on installation conditions.

Product Specifications
Table 17. 460 V heat pump dual module: 18–24 ton capacity

Model Name	4TVH0216B400NC		4TVH0240B400NC		4TVH0264B400NC		4TVH0288B400NC		
	4TVH0072B400NB + 4TVH0144B400NB		4TVH0072B400NB + 4TVH0168B400NC		4TVH0072B400NB + 4TVH0192B400NC		2x 4TVH0144B400NB		
Power Supply	460/60/3		460/60/3		460/60/3		460/60/3		
Nominal Tons	18.0		20.0		22.0		24.0		
System Type	Ducted	Non-Ducted	Ducted	Non-Ducted	Ducted	Non-Ducted	Ducted	Non-Ducted	
	Capacity (Nominal) ¹	Cooling Btu/h	216,000	216,000	240,000	240,000	264,000	288,000	288,000
Heating Btu/h		243,000	243,000	270,000	270,000	297,000	324,000	324,000	
Capacity (Rated) ²	Cooling Btu/h	206,000	206,000	228,000	228,000	252,000	276,000	276,000	
	High Temp Heating Btu/h	230,000	230,000	258,000	258,000	282,000	308,000	308,000	
Performance	Low Temp Heating Btu/h	150,000	150,000	168,000	168,000	184,000	200,000	200,000	
	EER	-	10.60	10.60	10.60	10.10	10.00	12.00	
AHRI -1230 Efficiency Ratings ²	IEER	-	20.50	20.10	19.60	21.90	21.60	22.00	
	COP@ 47°F	-	3.34	3.20	3.20	3.20	3.32	3.58	
	COP@ 17°F	-	2.31	2.40	2.40	2.17	2.35	2.48	
	SCHE	-	-	-	-	-	-	-	
Power	MCA	A		A		A		A	
	MOP	A		A		A		A	
	SCCR	kA		kA		kA		kA	
Compressor	Type (Qty.)	SSC Scroll (3)		SSC Scroll (3)		SSC Scroll (3)		SSC Scroll (4)	
	Model Name	DS-GB052FAVB5G x 3		DS-GB052FAVB5G x 3		DS-GB052FAVB5G x 1 + DS-GB066FAVB5G x 2		DS-GB052FAVB5G x 4	
Oil	Type	PVE		PVE		PVE		PVE	
	Initial Charge	341.5		341.5		341.5		419.2	

Each individual outdoor unit requires a separate electrical connection. Refer to the electrical data for each individual outdoor unit.

Table 17. 460 V heat pump dual module: 18–24 ton capacity (continued)

Model Name		4TVH0216B400NC		4TVH0240B400NC		4TVH0264B400NC		4TVH0288B400NC		
Individual Models		4TVH0072B400NB + 4TVH0144B400NB		4TVH0072B400NB + 4TVH0168B400NC		4TVH0072B400NB + 4TVH0192B400NC		2x 4TVH0144B400NB		
Power Supply		460/60/3		460/60/3		460/60/3		460/60/3		
Nominal Tons		18.0		20.0		22.0		24.0		
System Type		Ducted	Non-Ducted	Ducted	Non-Ducted	Ducted	Non-Ducted	Ducted	Non-Ducted	
Fan	Type (Qty.)	Propeller (3)		Propeller (3)		Propeller (3)		Propeller (4)		
	Output (Each)	630 + (620 x 2)		630 + (620 x 2)		630 + (620 x 2)		(620 x 2) + (620 X 2)		
	Airflow Rate	7,240 + 9,535		7,240 + 10,950		7,240 + 10,950		9535 x 2		
	External Static Pressure	0.31		0.31		0.31		0.31		
Piping Connections	Liquid Pipe	5/8 Braze		5/8 Braze		3/4 Braze		3/4 Braze		
	Gas Pipe	1-1/8 Braze		1-1/8 Braze		1-3/8 Braze		1-3/8 Braze		
Indoor Unit Connections	High Pressure Gas Pipe (for HR)	N/A		N/A		N/A		N/A		
	Installation Limits	Max Length ³	656 (722)		656 (722)		656 (722)		656 (722)	
		Max Height ⁴	361 (131)		361 (131)		361 (131)		361 (131)	
Refrigerant	Number of Connectable Indoor Units	37		41		45		49		
	Total Capacity (Cooling)	108,000 – 280,800		120,000 – 312,000		132,000 – 343,200		144,000 – 374,400		
Sound ⁵	Type	R410A		R410A		R410A		R410A		
	Factory Charge	31.3		36.4		36.4		38.4		
	Sound Pressure	64		65		65		65		
	Sound Power	84		86		87		86		

Table 17. 460 V heat pump dual module: 18–24 ton capacity (continued)

Model Name	4TVH0216B400NC		4TVH0240B400NC		4TVH0264B400NC		4TVH0288B400NC	
	4TVH0072B400NB + 4TVH0144B400NB		4TVH0072B400NB + 4TVH0168B400NC		4TVH0072B400NB + 4TVH0192B400NC		2x 4TVH0144B400NB	
Power Supply	460/60/3		460/60/3		460/60/3		460/60/3	
Nominal Tons	18.0		20.0		22.0		24.0	
System Type	Ducted	Non-Ducted	Ducted	Non-Ducted	Ducted	Non-Ducted	Ducted	Non-Ducted
	Net Weight	lbs. 425 + 657		lbs. 425 + 716		lbs. 425 + 734		lbs. 657 x 2
Shipping Weight	lbs. 461 + 699		lbs. 461 + 754		lbs. 461 + 772		lbs. 699 x 2	
Net Dimensions (WxHxD)	in. 34.65 x 66.73 x 30.12 + 50.98 x 66.73 x 30.12		in. 34.65 x 66.73 x 30.12 + 50.98 x 66.73 x 30.12		in. 34.65 x 66.73 x 30.12 + 50.98 x 66.73 x 30.12		in. (50.98 x 66.73 x 30.12) x 2	
Shipping Dimensions (WxHxD)	in. 37.32 x 75.28 x 32.76 + 53.66 x 75.28 x 32.76		in. 37.32 x 75.28 x 32.76 + 53.66 x 75.28 x 32.76		in. 37.32 x 75.28 x 32.76 + 53.66 x 75.28 x 32.76		in. (53.66 x 75.28 x 32.76) x 2	
Operating Temp Range	°F 23 to 120		°F 23 to 120		°F 23 to 120		°F 23 to 120	
	°F -13 to 75		°F -13 to 75		°F -13 to 75		°F -13 to 75	

Notes:

- Nominal capacity based on 25 ft (7.6 m) of equivalent refrigerant piping with 0 ft level difference.
 - Cooling:** Indoor temperature 80°F DB, 67°F WB/Outdoor temperature 95°F DB, 75°F WB
 - Heating:** Indoor temperature 70°F DB, 60°F WB/Outdoor temperature 47°F DB, 43°F WB
- Rated per AHRI-1230 Standard conditions
- Actual length (equivalent length in parenthesis)
- If the outdoor unit is installed above the indoor unit, the allowable height difference is 361 ft (110 m). If the outdoor unit is installed below the indoor unit, the allowable height difference is 131 ft (40 m).
- Sound pressure was acquired in a dead room. Actual noise level may be different depending on installation conditions.

Table 18. 460 V heat pump dual module: 26-32 ton capacity

Model Name		4TVH0312B400NC		4TVH0336B400NC		4TVH0360B400NC		4TVH0384B400NC			
Individual Models		4TVH0144B400NB + 4TVH0168B400NC		2x 4TVH0168B400NC		4TVH0168B400NC + 4TVH0192B400NC		2x 4TVH0192B400NC			
Power Supply		460/60/3		460/60/3		460/60/3		460/60/3			
Nominal Tons		26.0		28.0		30.0		32.0			
System Type		Ducted		Non-Ducted		Ducted		Non-Ducted			
Performance	Capacity (Nominal) ¹	Cooling	Btu/h	312,000	312,000	336,000	336,000	360,000	288,000	384,000	
		Heating	Btu/h	351,000	351,000	378,000	378,000	405,000	405,000	432,000	
		Cooling	Btu/h	298,000	298,000	320,000	320,000	344,000	344,000	366,000	
	Capacity (Rated) ²	High Temp Heating	Btu/h	334,000	334,000	360,000	360,000	386,000	386,000	410,000	
		Low Temp Heating	Btu/h	218,000	218,000	234,000	234,000	250,000	250,000	268,000	
	AHRI -1230 Efficiency Ratings ²	EER	-	9.90	9.90	9.80	9.80	9.70	9.70	9.70	9.70
		IEER	-	20.10	20.40	19.40	20.30	18.90	20.00	18.50	19.50
		COP@ 47°F	-	3.20	3.24	3.20	3.20	3.20	3.20	3.20	3.20
		COP@ 17°F	-	2.41	2.46	2.38	2.43	2.38	2.42	2.42	2.41
	Power	SCHE	-	-	-	-	-	-	-	-	-
MCA		A									
MOP		A									
Compressor	SCCR	kA									
	Type (Qty.)	-	SSC Scroll (4)	SSC Scroll (4)	SSC Scroll (4)	SSC Scroll (4)	SSC Scroll (4)	SSC Scroll (4)	SSC Scroll (4)	SSC Scroll (4)	
	Model Name	-	DS-GB052FAVB5G x 4	DS-GB052FAVB5G x 4	DS-GB052FAVB5G x 4	DS-GB052FAVB5G x 4	DS-GB052FAVB5G x 2 + DS-GB066FAVB5G x 2	DS-GB052FAVB5G x 4	DS-GB066FAVB5G x 4	DS-GB066FAVB5G x 4	
Oil	Type	-	PVE	PVE	PVE	PVE	PVE	PVE	PVE	PVE	
	Initial Charge	fl. oz.	419.2	419.2	419.2	419.2	419.2	419.2	419.2	419.2	

Each individual outdoor unit requires a separate electrical connection. Refer to the electrical data for each individual outdoor unit.

Table 18. 460 V heat pump dual module: 26-32 ton capacity (continued)

Model Name		4TVH0312B400NC		4TVH0336B400NC		4TVH0360B400NC		4TVH0384B400NC	
Individual Models		4TVH0144B400NB + 4TVH0168B400NC		2x 4TVH0168B400NC		4TVH0168B400NC + 4TVH0192B400NC		2x 4TVH0192B400NC	
Power Supply		460/60/3		460/60/3		460/60/3		460/60/3	
Nominal Tons		26.0		28.0		30.0		32.0	
System Type		Ducted	Non-Ducted	Ducted	Non-Ducted	Ducted	Non-Ducted	Ducted	Non-Ducted
Fan	Type (Qty.)	Propeller (4)		Propeller (4)		Propeller (4)		Propeller (4)	
	Output (Each)	(620 x 2) + (620 X 2)		(620 x 2) + (620 X 2)		(620 x 2) + (620 X 2)		(620 x 2) + (620 X 2)	
	Airflow Rate	9535 + 10,950		10,950 x 2		10,950 x 2		10,950 x 2	
	External Static Pressure	0.31		0.31		0.31		0.31	
Piping Connections	Liquid Pipe	3/4 Braze		3/4 Braze		3/4 Braze		3/4 Braze	
	Gas Pipe	1-3/8 Braze		1-3/8 Braze		1-5/8 Braze		1-5/8 Braze	
	High Pressure Gas Pipe (for HR)	N/A		N/A		N/A		N/A	
Indoor Unit Connections	Max Length ³	656 (722)		656 (722)		656 (722)		656 (722)	
	Max Height ⁴	361 (131)		361 (131)		361 (131)		361 (131)	
Refrigerant	Number of Connectable Indoor Units	54		58		62		64	
	Total Capacity (Cooling)	156,000 – 405,600		168,000 – 436,800		180,000 – 468,000		192,000 – 499,200	
Sound ⁵	Type	R410A		R410A		R410A		R410A	
	Factory Charge	43.4		48.5		48.5		48.5	
Sound ⁵	Sound Pressure	66		66		66		67	
	Sound Power	87		88		87		88	

Table 18. 460 V heat pump dual module: 26-32 ton capacity (continued)

Model Name	4TVH0312B400NC	4TVH0336B400NC	4TVH0360B400NC	4TVH0384B400NC	
Individual Models	4TVH0144B400NB + 4TVH0168B400NC	2x 4TVH0168B400NC	4TVH0168B400NC + 4TVH0192B400NC	2x 4TVH0192B400NC	
Power Supply	460/60/3	460/60/3	460/60/3	460/60/3	
Nominal Tons	26.0	28.0	30.0	32.0	
System Type	Ducted	Non-Ducted	Ducted	Non-Ducted	
External Dimensions	Net Weight	lbs.	657 + 717	717 x 2	734 x 2
	Shipping Weight	lbs.	699 + 754	754 x 2	772 x 2
Operating Temp Range	Net Dimensions (WxHxD)	in.	(50.98 x 66.73 x 30.12) x 2	(50.98 x 66.73 x 30.12) x 2	(50.98 x 66.73 x 30.12) x 2
	Shipping Dimensions (WxHxD)	in.	(53.66 x 75.28 x 32.76) x 2	(53.66 x 75.28 x 32.76) x 2	(53.66 x 75.28 x 32.76) x 2
Operating Range	Cooling	°F	23 to 120	23 to 120	23 to 120
	Heating	°F	-13 to 75	-13 to 75	-13 to 75

Notes:

- Nominal capacity based on 25 ft (7.6 m) of equivalent refrigerant piping with 0 ft level difference.
 - Cooling:** Indoor temperature 80°F DB, 67°F WB/Outdoor temperature 95°F DB, 75°F WB
 - Heating:** Indoor temperature 70°F DB, 60°F WB/Outdoor temperature 47°F DB, 43°F WB
- Rated per AHRI-1230 Standard conditions
- Actual length (equivalent length in parenthesis)
- If the outdoor unit is installed above the indoor unit, the allowable height difference is 361 ft (110 m). If the outdoor unit is installed below the indoor unit, the allowable height difference is 131 ft (40 m).
- Sound pressure was acquired in a dead room. Actual noise level may be different depending on installation conditions.

Product Specifications
Table 19. 460 V heat pump triple module: 34–38 ton capacity

Model Name		4TVH0408B400NC		4TVH0432B400NC		4TVH0456B400NC	
Individual Models		4TVH0072B400NB + 4TVH0144B400NB + 4TVH0192B400NC		3x 4TVH0144B400NB		4TVH0120B400NB + 2x 4TVH0168B400NC	
Power Supply		460/60/3		460/60/3		460/60/3	
Nominal Tons		34.0		36.0		38.0	
System Type		Ducted		Ducted		Ducted	
		Non-Ducted		Non-Ducted		Non-Ducted	
Performance	Capacity (Nominal) ¹	Cooling	Btu/h	408,000	408,000	432,000	456,000
	Capacity (Rated) ²	Heating	Btu/h	459,000	459,000	486,000	513,000
		Cooling	Btu/h	390,000	390,000	415,000	435,000
		High Temp Heating	Btu/h	435,000	435,000	460,000	490,000
	Low Temp Heating	Btu/h	284,000	284,000	300,000	320,000	
		EER	-	9.80	9.80	9.60	9.70
	AHRI -1230 Efficiency Ratings ²	IEER	-	17.80	17.00	19.10	16.60
		COP@ 47°F	-	3.20	3.20	3.20	3.22
		COP@ 17°F	-	2.36	2.36	2.28	2.17
	Power	MCA	A	-	-	-	-
MOP		A	-	-	-	-	
SCCR		kA	-	-	-	-	
Compressor	Type (Qty.)	-	SSC Scroll (5)	SSC Scroll (6)	SSC Scroll (5)	SSC Scroll (5)	
	Model Name	-	DS-GB052FAVBSG x 3 + DS-GB066FAVBSG x 2	DS-GB052FAVBSG x 6	DS-GB052FAVBSG x 4 + DS-GB066FAVBSG x 1	DS-GB052FAVBSG x 4 + DS-GB066FAVBSG x 1	
	Oil	Type	PVE	PVE	PVE	PVE	
	Initial Charge	fl. oz.	551.1	628.8	551.1	551.1	

Each individual outdoor unit requires a separate electrical connection. Refer to the electrical data for each individual outdoor unit.

Table 19. 460 V heat pump triple module: 34–38 ton capacity (continued)

Model Name		4TVH0408B400NC		4TVH0432B400NC		4TVH0456B400NC		
Individual Models		4TVH0072B400NB + 4TVH0144B400NB + 4TVH0192B400NC		3x 4TVH0144B400NB		4TVH0120B400NB + 2x 4TVH0168B400NC		
Power Supply		460/60/3		460/60/3		460/60/3		
Nominal Tons		34.0		36.0		38.0		
System Type		Ducted		Ducted		Ducted		
Type (Qty.)		Propeller (6)		Propeller (6)		Propeller (6)		
Fan	Output (Each)	W		(620 x 2) + (620 x 2) + (620 X 2)		(620 x 2) + (620 x 2) + (620 X 2)		
	Airflow Rate	CFM		7,240 + 9,535 + 10,950		9,180 + (10,950 x 2)		
	External Static Pressure	in. WG		0.31		0.31		
	Liquid Pipe	dia. in.		3/4 Braze		3/4 Braze		
	Gas Pipe	dia. in.		1-5/8 Braze		1-5/8 Braze		
Piping Connections	High Pressure Gas Pipe (for HR)	dia. in.		N/A		N/A		
	Installation Limits	Max Length ³	ft		656 (722)		656 (722)	
		Max Height ⁴	ft		361 (131)		361 (131)	
Indoor Unit Connections	Number of Connectable Indoor Units	-		64		64		
	Total Capacity (Cooling)	Btu/h		204,000 – 530,400		216,000 – 561,600		
Refrigerant	Type	-		R410A		R410A		
	Factory Charge	lbs.		55.6		57.5		
Sound ⁵	Sound Pressure	dB(A)		67		67		
	Sound Power	dB(A)		88		88		

Table 19. 460 V heat pump triple module: 34–38 ton capacity (continued)

Model Name		4TVH0408B400NC	4TVH0432B400NC	4TVH0456B400NC
Individual Models		4TVH0072B400NB + 4TVH0144B400NB + 4TVH0192B400NC	3x 4TVH0144B400NB	4TVH0120B400NB + 2x 4TVH0168B400NC
Power Supply		460/60/3		
Nominal Tons		38.0		
System Type		36.0		
		Ducted	Non-Ducted	Ducted
Net Weight		lbs.		
Shipping Weight		lbs.		
External Dimensions (WxHxD)		in.		
Shipping Dimensions (WxHxD)		in.		
Operating Temp Range		°F		
		°F		

		460/60/3	36.0	38.0
Net Weight		425 + 657 + 734		
Shipping Weight		461 + 699 + 772		
External Dimensions (WxHxD)		34.65 x 66.73 x 30.12 + (50.98 x 66.73 x 30.12) x 2		
Shipping Dimensions (WxHxD)		37.32 x 75.29 x 32.76 + (53.66 x 75.28 x 32.76) x 2		
Operating Temp Range		23 to 120		
		-13 to 75		

		460/60/3	36.0	38.0
Net Weight		624 + (717 x 2)		
Shipping Weight		666 + (754 x 2)		
External Dimensions (WxHxD)		(50.98 x 66.73 x 30.12) x 3		
Shipping Dimensions (WxHxD)		(53.66 x 75.28 x 32.76) x 3		
Operating Temp Range		23 to 120		
		-13 to 75		

Notes:

- Nominal capacity based on 25 ft (7.6 m) of equivalent refrigerant piping with 0 ft level difference.
 - Cooling:** Indoor temperature 80°F DB, 67°F WB/Outdoor temperature 95°F DB, 75°F WB
 - Heating:** Indoor temperature 70°F DB, 60°F WB/Outdoor temperature 47°F DB, 43°F WB
- Rated per AHRI-1230 Standard conditions
- Actual length (equivalent length in parenthesis)
- If the outdoor unit is installed above the indoor unit, the allowable height difference is 361 ft (110 m). If the outdoor unit is installed below the indoor unit, the allowable height difference is 131 ft (40 m).
- Sound pressure was acquired in a dead room. Actual noise level may be different depending on installation conditions.

Table 20. 460 V heat pump triple modules: 40–44 ton capacity

Model Name		4TVH0480B400NC		4TVH0504B400NC		4TVH0528B400NC			
Individual Models		4TVH0144B400NB + 2x 4TVH0168B400NC		3x 4TVH0168B400NC		2x 4TVH0168B400NC + 4TVH0192B400NC			
Power Supply		460/60/3		460/60/3		460/60/3			
Nominal Tons		40.0		42.0		44.0			
System Type		Ducted		Non-Ducted		Ducted		Non-Ducted	
Performance	Capacity (Nominal) ¹	Cooling	Btu/h	480,000	480,000	504,000	504,000	528,000	528,000
		Heating	Btu/h	540,000	540,000	567,000	567,000	594,000	594,000
	Capacity (Rated) ²	Cooling	Btu/h	455,000	455,000	480,000	480,000	500,000	500,000
		High Temp Heating	Btu/h	510,000	510,000	535,000	535,000	560,000	560,000
	Low Temp Heating	Btu/h	332,000	332,000	348,000	348,000	364,000	364,000	
		EER	-	9.60	9.60	9.60	9.60	9.50	9.50
	AHRI - 1230 Efficiency Ratings ²	IEER	-	16.60	18.60	16.40	18.40	16.00	18.00
		COP@ 47°F	-	3.21	3.21	3.21	3.21	3.20	3.20
		COP@ 17°F	-	2.13	2.23	2.11	2.21	2.10	2.05
		SCHE	-	-	-	-	-	-	-
Power	MCA	A	Each individual outdoor unit requires a separate electrical connection. Refer to the electrical data for each individual outdoor unit.						
	MOP	A							
	SCCR	kA							
Compressor	Type (Qty.)	-	SSC Scroll (6)		SSC Scroll (6)		SSC Scroll (6)		
	Model Name	-	DS-GB052FAVBSSG x 6		DS-GB052FAVBSSG x 6		DS-GB052FAVBSSG x 4 + DS-GB066FAVBSSG x 2		
	Type	-	PVE		PVE		PVE		
	Oil	Initial Charge	628.8	628.8		628.8			628.8

Product Specifications
Table 20. 460 V heat pump triple modules: 40–44 ton capacity (continued)

Model Name	4TVH0480B400NC		4TVH0504B400NC		4TVH0528B400NC	
Individual Models	4TVH0144B400NB + 2x 4TVH0168B400NC		3x 4TVH0168B400NC		2x 4TVH0168B400NC + 4TVH0192B400NC	
Power Supply	460/60/3		460/60/3		460/60/3	
Nominal Tons	40.0		42.0		44.0	
System Type	Ducted	Non-Ducted	Ducted	Non-Ducted	Ducted	Non-Ducted
Fan	Type (Qty.)	-	Propeller (6)		Propeller (6)	
	Output (Each)	W	(620 x 2) + (620 x 2) + (620 X 2)		(620 x 2) + (620 x 2) + (620 X 2)	
	Airflow Rate	CFM	9,535 + (10,950 x 2)		10,950 x 3	
	External Static Pressure	in. WG	0.31		0.31	
Piping Connections	Liquid Pipe	dia. in.	3/4 Braze		3/4 Braze	
	Gas Pipe	dia. in.	1-5/8 Braze		1-5/8 Braze	
	High Pressure Gas Pipe (for HR)	dia. in.	N/A		N/A	
	Installation Limits	Max Length ³	ft	656 (722)		656 (722)
Max Height ⁴		ft	361 (131)		361 (131)	
Indoor Unit Connections	Number of Connectable Indoor Units	-	64		64	
	Total Capacity (Cooling)	Btu/h	240,000 – 624,000		252,000 – 655,200	
Refrigerant	Type	-	R410A		R410A	
	Factory Charge	lbs.	67.9		72.8	
Sound ⁵	Sound Pressure	dB(A)	67		68	
	Sound Power	dB(A)	89		90	
External Dimensions	Net Weight	lbs.	657 + (717 x 2)		717 x 3	
	Shipping Weight	lbs.	699 + (754 x 2)		754 x 3	
	Net Dimensions (WxHxD)	in.	(50.98 x 66.73 x 30.12) x 3		(50.98 x 66.73 x 30.12) x 3	
	Shipping Dimensions (WxHxD)	in.	(53.66 x 75.28 x 32.76) x 3		(53.66 x 75.28 x 32.76) x 3	

Table 20. 460 V heat pump triple modules: 40–44 ton capacity (continued)

Model Name		4TVH0480B400NC	4TVH0504B400NC	4TVH0528B400NC	
Individual Models		4TVH0144B400NB + 2x 4TVH0168B400NC	3x 4TVH0168B400NC	2x 4TVH0168B400NC + 4TVH0192B400NC	
Power Supply		460/60/3	460/60/3	460/60/3	
Nominal Tons		40.0	42.0	44.0	
System Type		Ducted	Non-Ducted	Ducted	Non-Ducted
Operating Temp Range	Cooling	°F	23 to 120	23 to 120	23 to 120
	Heating	°F	-13 to 75	-13 to 75	-13 to 75

Notes:

- Nominal capacity based on 25 ft (7.6 m) of equivalent refrigerant piping with 0 ft level difference.
 - Cooling:** Indoor temperature 80°F DB, 67°F WB/Outdoor temperature 95°F DB, 75°F WB
 - Heating:** Indoor temperature 70°F DB, 60°F WB/Outdoor temperature 47°F DB, 43°F WB
- Rated per AHRI-1230 Standard conditions
- Actual length (equivalent length in parenthesis)
- If the outdoor unit is installed above the indoor unit, the allowable height difference is 361 ft (110 m). If the outdoor unit is installed below the indoor unit, the allowable height difference is 131 ft (40 m).
- Sound pressure was acquired in a dead room. Actual noise level may be different depending on installation conditions.

Product Specifications
Table 21. 460 V heat recovery single: 6–10 ton capacity

Model Name		4TVR0072B400NB		4TVR0096B400NB		4TVR0120B400NB		
Power Supply		460/60/3		460/60/3		460/60/3		
Nominal Tons		6.0		8.0		10.0		
System Type		6.0		8.0		10.0		
		Ducted	Non-Ducted	Ducted	Non-Ducted	Ducted	Non-Ducted	
Performance	Capacity (Nominal) ¹	Cooling Btu/h	72,000	72,000	96,000	96,000	120,000	
		Heating Btu/h	81,000	81,000	108,000	108,000	135,000	
	Capacity (Rated) ²	Cooling Btu/h	69,000	69,000	92,000	92,000	114,000	
		High Temp Heating Btu/h	77,000	77,000	103,000	103,000	129,000	
	AHRI -1230 Efficiency Ratings ²	Low Temp Heating Btu/h	51,000	51,000	67,000	67,000	84,000	
		EER	-	11.50	14.60	11.60	13.90	12.40
		IEER	-	22.50	33.00	22.40	31.00	28.70
		COP@ 47°F	-	3.46	4.35	3.60	4.23	3.97
		COP@ 17°F	-	2.49	2.75	2.47	2.81	2.53
		SCHE	-	27.00	29.00	27.50	31.50	30.00
Power	MCA	A	16.4	19.0	21.7			
	MOP	A	20	25	30			
	SCCR	kA	5	5	5			
Compressor	Type (Qty.)	-	SSC Scroll (1)	SSC Scroll (1)	SSC Scroll (1)	SSC Scroll (1)		
	Model Name	-	DS-GB052FAVBGS	DS-GB066FAVBGS	DS-GB066FAVBGS	DS-GB066FAVBGS		
	Oil	Type	PVE	PVE	PVE	PVE		
Fan	Type (Qty.)	Initial Charge	fl. oz.	131.9	131.9	131.9	131.9	
		Output (Each)	W	630	620	620		
	Airflow Rate	CFM	7,240	9,180	9,180			
	External Static Pressure	in. WG	0.31	0.31	0.31			

Table 21. 460 V heat recovery single: 6–10 ton capacity (continued)

Model Name	4TVR0072B400NB		4TVR0096B400NB		4TVR0120B400NB	
Power Supply	460/60/3		460/60/3		460/60/3	
Nominal Tons	6.0		8.0		10.0	
System Type	Ducted	Non-Ducted	Ducted	Non-Ducted	Ducted	Non-Ducted
Piping Connections	Liquid Pipe	dia. in.	3/8 Braze	3/8 Braze	1/2 Braze	1/2 Braze
	Gas Pipe	dia. in.	3/4 Braze	7/8 Braze	1-1/8 Braze	1-1/8 Braze
	High Pressure Gas Pipe (for HR)	dia. in.	5/8 Braze	3/4 Braze	7/8 Braze	7/8 Braze
	Installation Limits	Max Length ³	ft	656 (722)	656 (722)	656 (722)
Max Height ⁴		ft	361 (131)	361 (131)	361 (131)	361 (131)
Indoor Unit Connections	Number of Connectable Indoor Units	-	12	16	20	20
Refrigerant	Total Capacity (Cooling)	Btu/h	36,000 – 93,600	48,000 – 124,800	60,000 – 156,000	60,000 – 156,000
	Type	-	R410A	R410A	R410A	R410A
	Factory Charge	lbs.	12.1	16.3	16.3	16.3
Sound ⁵	Sound Pressure	dB(A)	60.0	61.0	61.0	61.0
	Sound Power	dB(A)	81	81	81	81
	Net Weight	lbs.	445	553	553	553
External Dimensions	Shipping Weight	lbs.	481	595	595	595
	Net Dimensions (WxHxD)	in.	34.65 x 66.73 x 30.12	50.98 x 66.73 x 30.12	50.98 x 66.73 x 30.12	50.98 x 66.73 x 30.12
	Shipping Dimensions (WxHxD)	in.	37.32 x 75.28 x 32.76	53.66 x 75.28 x 32.76	53.66 x 75.28 x 32.76	53.66 x 75.28 x 32.76
	Operating Temp Range	Cooling ⁶	°F	5 to 120	5 to 120	5 to 120
Heating		°F	-13 to 75	-13 to 75	-13 to 75	-13 to 75

Table 21. 460 V heat recovery single: 6–10 ton capacity (continued)

Model Name	4TVR0072B400NB		4TVR0096B400NB		4TVR0120B400NB	
	Ducted	Non-Ducted	Ducted	Non-Ducted	Ducted	Non-Ducted
Power Supply	460/60/3		460/60/3		460/60/3	
Nominal Tons	6.0		8.0		10.0	
System Type	Ducted	Non-Ducted	Ducted	Non-Ducted	Ducted	Non-Ducted

Notes:

- Nominal capacity based on 25 ft (7.6 m) of equivalent refrigerant piping with 0 ft level difference.
 - Cooling:** Indoor temperature 80°F DB, 67°F WB/Outdoor temperature 95°F DB, 75°F WB
 - Heating:** Indoor temperature 70°F DB, 60°F WB/Outdoor temperature 47°F DB, 43°F WB
- Rated per AHRI-1230 Standard conditions
- Actual length (equivalent length in parenthesis)
 - If the outdoor unit is installed above the indoor unit, the allowable height difference is 361 ft (110 m). If the outdoor unit is installed below the indoor unit, the allowable height difference is 131 ft (40 m).
- Sound pressure was acquired in a dead room. Actual noise level may be different depending on installation conditions.
- Refer to the "Outdoor Unit Operation Limits" section of this document.

Table 22. 460 V heat recovery single modules: 12–16 ton capacity

Model Name		4TVR0144B400NB		4TVR0168B400NC		4TVR0192B400NC			
Power Supply		460/60/3		460/60/3		460/60/3			
Nominal Tons		12.0		14.0		16.0			
System Type		Ducted		Non-Ducted		Ducted		Non-Ducted	
		Capacity (Nominal) ¹	Cooling	144,000	144,000	168,000	168,000	192,000	192,000
	Heating	162,000	162,000	189,000	189,000	216,000	216,000	216,000	216,000
Capacity (Rated) ²	Cooling	138,000	138,000	160,000	160,000	184,000	184,000	184,000	184,000
	High Temp Heating	154,000	154,000	180,000	180,000	206,000	206,000	206,000	206,000
Performance	Low Temp Heating	100,000	100,000	118,000	118,000	134,000	134,000	134,000	134,000
	EER	-	11.70	10.60	10.60	10.60	10.60	10.60	10.60
	IEER	-	21.60	20.80	20.80	21.00	21.00	21.00	23.00
	AHRI -1230 COP@ 47°F	-	3.54	3.81	3.21	3.65	3.20	3.20	3.50
	AHRI -1230 COP@ 17°F	-	2.42	2.55	2.25	2.50	2.20	2.20	2.45
	SCHE	-	26.00	27.50	25.00	26.50	23.50	23.50	26.00
	MCA	A	28.7	33.0	37.0	37.0	37.0	37.0	37.0
Power	MOP	A	40	40	40	50	50	50	50
	SCCR	kA	5	5	5	5	5	5	5
	Type (Qty.)	-	SSC Scroll (2)	SSC Scroll (2)	SSC Scroll (2)	SSC Scroll (2)	SSC Scroll (2)	SSC Scroll (2)	SSC Scroll (2)
Compressor	Model Name	-	DS-GB052FAVBSSG	DS-GB052FAVBSSG	DS-GB052FAVBSSG	DS-GB066FAVBSSG	DS-GB066FAVBSSG	DS-GB066FAVBSSG	DS-GB066FAVBSSG
	Type	-	PVE	PVE	PVE	PVE	PVE	PVE	PVE
	Oil	Initial Charge	209.6	209.6	209.6	209.6	209.6	209.6	209.6
Fan	Type (Qty.)	-	Propeller (2)	Propeller (2)	Propeller (2)	Propeller (2)	Propeller (2)	Propeller (2)	Propeller (2)
	Output (Each)	W	620	620	620	620	620	620	620
	Airflow Rate	CFM	9,535	10,950	10,950	10,950	10,950	10,950	10,950
	External Static Pressure	in. WG	0.31	0.31	0.31	0.31	0.31	0.31	0.31

Product Specifications
Table 22. 460 V heat recovery single modules: 12–16 ton capacity (continued)

Model Name		4TVR0144B400NB		4TVR0168B400NC		4TVR0192B400NC			
Power Supply		460/60/3		460/60/3		460/60/3			
Nominal Tons		12.0		14.0		16.0			
System Type		Ducted		Non-Ducted		Ducted		Non-Ducted	
Piping Connections	Liquid Pipe	dia. in.	1/2 Braze	5/8 Braze		5/8 Braze		5/8 Braze	
	Gas Pipe	dia. in.	1-1/8 Braze	1-1/8 Braze		1-1/8 Braze		1-1/8 Braze	
	High Pressure Gas Pipe (for HR)	dia. in.	7/8 Braze	7/8 Braze		7/8 Braze		1-1/8 Braze	
	Installation Limits	Max Length ³	ft	656 (722)	656 (722)		656 (722)		656 (722)
Max Height ⁴		ft	361 (131)	361 (131)		361 (131)		361 (131)	
Indoor Unit Connections	Number of Connectable Indoor Units	-	25	29		33			
	Total Capacity (Cooling)	Btu/h	72,000 – 187,200	84,000 – 218,400		96,000 – 249,600			
Refrigerant	Type	-	R410A	R410A		R410A			
	Factory Charge	lbs.	19.2	24.3		24.3			
Sound ⁵	Sound Pressure	dB(A)	62.0	63.0		64.0			
	Sound Power	dB(A)	83	85		86			
	Net Weight	lbs.	692	736		752			
External Dimensions	Shipping Weight	lbs.	734	772		790			
	Net Dimensions (WxHxD)	in.	50.98 x 66.73 x 30.12	50.98 x 66.73 x 30.12		50.98 x 66.73 x 30.12			
	Shipping Dimensions (WxHxD)	in.	53.66 x 75.28 x 32.76	53.66 x 75.28 x 32.76		53.66 x 75.28 x 32.76			
Operating Temp Range	Cooling ⁶	°F	5 to 120	5 to 120		5 to 120			
	Heating	°F	-13 to 75	-13 to 75		-13 to 75			

Table 22. 460 V heat recovery single modules: 12–16 ton capacity (continued)

Model Name	4TVR0144B400NB		4TVR0168B400NC		4TVR0192B400NC	
	460/60/3	Non-Ducted	Ducted	Non-Ducted	Ducted	Non-Ducted
Power Supply	460/60/3		460/60/3		460/60/3	
Nominal Tons	12.0		14.0		16.0	
System Type	Ducted	Non-Ducted	Ducted	Non-Ducted	Ducted	Non-Ducted

Notes:

1. Nominal capacity based on 25 ft (7.6 m) of equivalent refrigerant piping with 0 ft level difference.
 - **Cooling:** Indoor temperature 80°F DB, 67°F WB/Outdoor temperature 95°F DB, 75°F WB
 - **Heating:** Indoor temperature 70°F DB, 60°F WB/Outdoor temperature 47°F DB, 43°F WB
2. Rated per AHRI-1230 Standard conditions
3. Actual length (equivalent length in parenthesis)
 4. If the outdoor unit is installed above the indoor unit, the allowable height difference is 361 ft (110 m). If the outdoor unit is installed below the indoor unit, the allowable height difference is 131 ft (40 m).
5. Sound pressure was acquired in a dead room. Actual noise level may be different depending on installation conditions.
6. Refer to the "Outdoor Unit Operation Limits" section of this document.

Table 23. 460 V heat recovery dual modules: 18–24 ton capacity

Model Name		4TVR0216B400NC		4TVR0240B400NC		4TVR0264B400NC		4TVR0288B400NC		
Individual Models		4TVR0072B400NB + 4TVR0144B400NB		4TVR0072B400NB + 4TVR0168B400NC		4TVR0072B400NB + 4TVR0192B400NC		2x 4TVH0144B400NB		
Power Supply		460/60/3		460/60/3		460/60/3		460/60/3		
Nominal Tons		18.0		20.0		22.0		24.0		
System Type	Capacity (Nominal) ¹	Ducted	Non-Ducted	Ducted	Non-Ducted	Ducted	Non-Ducted	Ducted	Non-Ducted	
		Btu/h	Btu/h	Btu/h	Btu/h	Btu/h	Btu/h	Btu/h	Btu/h	
Performance	Capacity (Rated) ²	Cooling	216,000	243,000	240,000	270,000	240,000	270,000	264,000	297,000
		Heating	243,000	206,000	270,000	228,000	270,000	228,000	297,000	324,000
Performance	Capacity (Rated) ²	Cooling	230,000	230,000	258,000	258,000	258,000	258,000	282,000	282,000
		High Temp Heating	230,000	230,000	258,000	258,000	258,000	258,000	282,000	282,000
Performance	Capacity (Rated) ²	Low Temp Heating	150,000	150,000	168,000	168,000	168,000	168,000	184,000	184,000
		Heating	150,000	150,000	168,000	168,000	168,000	168,000	184,000	184,000
Performance	Capacity (Rated) ²	EER	10.60	10.80	10.60	10.60	10.60	10.60	10.10	10.10
		IEER	20.50	23.40	20.10	22.00	19.60	21.90	21.60	22.00
Performance	Capacity (Rated) ²	COP@ 47°F	3.34	3.63	3.20	3.51	3.20	3.35	3.32	3.58
		COP@ 17°F	2.31	2.52	2.40	2.38	2.17	2.31	2.36	2.48
Performance	Capacity (Rated) ²	SCHE	20.50	23.40	20.50	23.50	20.50	23.50	21.50	23.50
		SCHE	20.50	23.40	20.50	23.50	20.50	23.50	21.50	23.50
Power	MCA	A								
	MOP	A								
	SCCR	kA								
Compressor	Type (Qty.)	SSC Scroll (3)		SSC Scroll (3)		SSC Scroll (3)		SSC Scroll (4)		
	Model Name	DS-GB052FAVB5G x 3		DS-GB052FAVB5G x 3		DS-GB052FAVB5G x 1 + DS-GB066FAVB5G X 2		DS-GB052FAVB5G x 4		
Oil	Type	PVE		PVE		PVE		PVE		
	Initial Charge	fl. oz.		fl. oz.		fl. oz.		fl. oz.		

Each individual outdoor unit requires a separate electrical connection. Refer to the electrical data for each individual outdoor unit.

Table 23. 460 V heat recovery dual modules: 18–24 ton capacity (continued)

Model Name		4TVR0216B400NC		4TVR0240B400NC		4TVR0264B400NC		4TVR0288B400NC	
Individual Models		4TVR0072B400NB + 4TVR0144B400NB		4TVR0072B400NB + 4TVR0168B400NC		4TVR0072B400NB + 4TVR0192B400NC		2x 4TVH0144B400NB	
Power Supply		460/60/3		460/60/3		460/60/3		460/60/3	
Nominal Tons		18.0		20.0		22.0		24.0	
System Type		Ducted	Non-Ducted	Ducted	Non-Ducted	Ducted	Non-Ducted	Ducted	Non-Ducted
Fan	Type (Qty.)	Propeller (3)		Propeller (3)		Propeller (3)		Propeller (4)	
	Output (Each)	630 + (620 x 2)		630 + (620 x 2)		630 + (620 x 2)		(620 x 2) + (620 X 2)	
	Airflow Rate	7,240 + 9,535		7,240 + 10,950		7,240 + 10,950		9,352 x 2	
	External Static Pressure	0.31		0.31		0.31		0.31	
Piping Connections	Liquid Pipe	5/8 Braze		5/8 Braze		5/8 Braze		3/4 Braze	
	Gas Pipe	1-1/8 Braze		1-1/8 Braze		1-1/8 Braze		1-3/8 Braze	
	High Pressure Gas Pipe (for HR)	1-1/8 Braze		1-1/8 Braze		1-1/8 Braze		1-1/8 Braze	
	Installation Limits	Max Length ³	656 (722)		656 (722)		656 (722)		656 (722)
Indoor Unit Connections	Max Height ⁴	361 (131)		361 (131)		361 (131)		361 (131)	
	Number of Connectable Indoor Units	37		41		45		49	
	Total Capacity (Cooling)	108,000 – 280,800		120,000 – 312,000		132,000 – 343,200		144,000 – 374,400	
	Type	R410A		R410A		R410A		R410A	
Refrigerant	Factory Charge	31.3		36.4		36.4		38.4	
	Sound Pressure	64		65		65		65	
Sound ⁵	Sound Power	84		86		87		86	

Table 23. 460 V heat recovery dual modules: 18–24 ton capacity (continued)

Model Name	4TVR0216B400NC		4TVR0240B400NC		4TVR0264B400NC		4TVR0288B400NC	
	4TVR0072B400NB + 4TVR0144B400NB		4TVR0072B400NB + 4TVR0168B400NC		4TVR0072B400NB + 4TVR0192B400NC		2x 4TVH0144B400NB	
Power Supply	460/60/3		460/60/3		460/60/3		460/60/3	
Nominal Tons	18.0		20.0		22.0		24.0	
System Type	Ducted	Non-Ducted	Ducted	Non-Ducted	Ducted	Non-Ducted	Ducted	Non-Ducted
	External Dimensions	Net Weight	lbs.	430 + 672	430 + 732	430 + 750	672 x 2	
Shipping Weight		lbs.	465 + 714	465 + 770	465 + 788	714 x 2		
Operating Temp Range	Net Dimensions (WxHxD)	in.	(34.65 x 66.73 x 30.12) + (50.98 x 66.73 x 30.12)	(34.65 x 66.73 x 30.12) + (50.98 x 66.73 x 30.12)	(34.65 x 66.73 x 30.12) + (50.98 x 66.73 x 30.12)	(50.98 x 66.73 x 30.12) x 2		
	Shipping Dimensions (WxHxD)	in.						
Operating Temp Range	Cooling ⁶	°F	5 to 120	5 to 120	5 to 120	5 to 120	5 to 120	5 to 120
	Heating	°F	-13 to 75	-13 to 75	-13 to 75	-13 to 75	-13 to 75	-13 to 75

Notes:

- Nominal capacity based on 25 ft (7.6 m) of equivalent refrigerant piping with 0 ft level difference.
 - Cooling:** Indoor temperature 80°F DB, 67°F WB/Outdoor temperature 95°F DB, 75°F WB
 - Heating:** Indoor temperature 70°F DB, 60°F WB/Outdoor temperature 47°F DB, 43°F WB
- Rated per AHRI-1230 Standard conditions
- Actual length (equivalent length in parenthesis)
- If the outdoor unit is installed above the indoor unit, the allowable height difference is 361 ft (110 m). If the outdoor unit is installed below the indoor unit, the allowable height difference is 131 ft (40 m).
- Sound pressure was acquired in a dead room. Actual noise level may be different depending on installation conditions.
- Refer to the "Outdoor Unit Operation Limits" section of this document.

Table 24. 460 V heat recovery dual modules: 26–32 ton capacity

Model Name		4TVH0312B400NC		4TVR0336B400NC		4TVR0360B400NC		4TVR0384B400NC			
Individual Models		4TVR0144B400NB + 4TVR0168B400NC		2x 4TVR0168B400NC		4TVR0144B400NC + 4TVR0192B400NC		2x 4TVR0192B400NC			
Power Supply		460/60/3		460/60/3		460/60/3		460/60/3			
Nominal Tons		26.0		28.0		30.0		32.0			
System Type		Ducted		Non-Ducted		Ducted		Non-Ducted			
Performance	Capacity (Nominal) ¹	Cooling	Btu/h	312,000	312,000	336,000	336,000	360,000	288,000	384,000	
		Heating	Btu/h	351,000	351,000	378,000	378,000	405,000	405,000	432,000	
		Cooling	Btu/h	298,000	298,000	320,000	320,000	344,000	344,000	366,000	
	Capacity (Rated) ²	High Temp Heating	Btu/h	334,000	334,000	360,000	360,000	386,000	386,000	410,000	
		Low Temp Heating	Btu/h	218,000	218,000	234,000	234,000	250,000	250,000	268,000	
	AHRI -1230 Efficiency Ratings ²	EER	-	9.90	9.90	9.80	9.80	9.80	9.70	9.70	9.70
		IEER	-	20.10	20.40	19.40	20.30	18.90	20.00	19.50	
		COP@ 47°F	-	3.20	3.24	3.20	3.20	3.20	3.20	3.20	3.20
		COP@ 17°F	-	2.41	2.46	2.38	2.43	2.38	2.42	2.42	2.41
		SCHE	-	20.50	23.50	20.50	23.10	19.70	22.40	19.00	22.00
Power	MCA	A									
	MOP	A									
	SCCR	kA									
Compressor	Type (Qty.)	-	SSC Scroll (4)	SSC Scroll (4)	SSC Scroll (4)	SSC Scroll (4)	SSC Scroll (4)	SSC Scroll (4)	SSC Scroll (4)		
	Model Name	-	DS-GB052FAVB5G x 4	DS-GB052FAVB5G x 4	DS-GB052FAVB5G x 4	DS-GB052FAVB5G x 2 + DS-GB066FAVB5G X 2	DS-GB052FAVB5G x 4	DS-GB052FAVB5G x 2 + DS-GB066FAVB5G X 2	DS-GB066FAVB5G X 4		
	Oil	Type	PVE	PVE	PVE	PVE	PVE	PVE	PVE		
	Initial Charge	fl. oz.									

Each individual outdoor unit requires a separate electrical connection. Refer to the electrical data for each individual outdoor unit.

Table 24. 460 V heat recovery dual modules: 26–32 ton capacity (continued)

Model Name		4TVH0312B400NC		4TVR0336B400NC		4TVR0360B400NC		4TVR0384B400NC	
Individual Models		4TVR0144B400NC + 4TVR0168B400NC		2x 4TVR0168B400NC		4TVR0144B400NC + 4TVR0192B400NC		2x 4TVR0192B400NC	
Power Supply		460/60/3		460/60/3		460/60/3		460/60/3	
Nominal Tons		26.0		28.0		30.0		32.0	
System Type		Ducted	Non-Ducted	Ducted	Non-Ducted	Ducted	Non-Ducted	Ducted	Non-Ducted
Fan	Type (Qty.)	Propeller (4)		Propeller (4)		Propeller (4)		Propeller (4)	
	Output (Each)	(620 x 2) + (620 X 2)		(620 x 2) + (620 X 2)		(620 x 2) + (620 X 2)		(620 x 2) + (620 X 2)	
	Airflow Rate	9,535 + 10,950		10,950 x 2		10,950 x 2		10,950 x 2	
	External Static Pressure	0.31		0.31		0.31		0.31	
Piping Connections	Liquid Pipe	3/4 Braze		3/4 Braze		3/4 Braze		3/4 Braze	
	Gas Pipe	1-3/8 Braze		1-3/8 Braze		1-5/8 Braze		1-5/8 Braze	
	High Pressure Gas Pipe (for HR)	1-1/8 Braze		1-1/8 Braze		1-3/8 Braze		1-3/8 Braze	
	Installation Limits	Max Length ³	656 (722)	656 (722)	656 (722)	656 (722)	656 (722)	656 (722)	656 (722)
Indoor Unit Connections	Max Height ⁴	361 (131)	361 (131)	361 (131)	361 (131)	361 (131)	361 (131)	361 (131)	361 (131)
	Number of Connectable Indoor Units	54		58		62		64	
	Total Capacity (Cooling)	156,000 – 405,600		168,000 – 436,800		180,000 – 468,000		192,000 – 499,200	
	Type	R410A		R410A		R410A		R410A	
Refrigerant	Factory Charge	43.4		48.5		48.5		48.5	
	Sound Pressure	66		66		66		66	
Sound ⁵	Sound Power	97		88		87		88	

Table 24. 460 V heat recovery dual modules: 26–32 ton capacity (continued)

Model Name	4TVH0312B400NC	4TVR0336B400NC	4TVR0360B400NC	4TVR0384B400NC
Individual Models	4TVR0144B400NC + 4TVR0168B400NC	2x 4TVR0168B400NC	4TVR0144B400NC + 4TVR0192B400NC	2x 4TVR0192B400NC
Power Supply	460/60/3	460/60/3	460/60/3	460/60/3
Nominal Tons	26.0	28.0	30.0	32.0
System Type	Ducted	Non-Ducted	Ducted	Non-Ducted
External Dimensions	Net Weight	lbs.	672 + 732	732 x 2
	Shipping Weight	lbs.	714 + 770	770 x 2
	Net Dimensions (WxHxD)	in.	(50.98 x 66.73 x 30.12) x 2	(50.98 x 66.73 x 30.12) x 2
	Shipping Dimensions (WxHxD)	in.	(50.98 x 66.73 x 30.12) x 2	(50.98 x 66.73 x 30.12) x 2
Operating temp Range	Cooling ⁶	°F	5 to 120	5 to 120
	HEATING	°F	-13 to 75	-13 to 75

Notes:

- Nominal capacity based on 25 ft (7.6 m) of equivalent refrigerant piping with 0 ft level difference.
 - Cooling:** Indoor temperature 80°F DB, 67°F WB/Outdoor temperature 95°F DB, 75°F WB
 - Heating:** Indoor temperature 70°F DB, 60°F WB/Outdoor temperature 47°F DB, 43°F WB
- Rated per AHRI-1230 Standard conditions
- Actual length (equivalent length in parenthesis)
- If the outdoor unit is installed above the indoor unit, the allowable height difference is 361 ft (110 m). If the outdoor unit is installed below the indoor unit, the allowable height difference is 131 ft (40 m).
- Sound pressure was acquired in a dead room. Actual noise level may be different depending on installation conditions.
- Refer to the "Outdoor Unit Operation Limits" section of this document.

Product Specifications
Table 25. 460 V heat recovery triple module: 34–38 ton capacity

Model Name	4TVR0408B400NC		4TVR0432B400NC		4TVR0456B400NC				
Individual Models	4TVR0072B400NB + 4TVR0144B400NB + 4TVR0192B400NC		3x 4TVR0144B400NB		4TVR0120B400NB + 2x 4TVR0168B400NC				
Power Supply	460/60/3		460/60/3		460/60/3				
Nominal Tons	34.0		36.0		38.0				
System Type	Ducted		Non-Ducted		Ducted		Non-Ducted		
	Performance	Capacity (Nominal) ¹	Cooling Btu/h	408,000	408,000	432,000	432,000	456,000	456,000
Capacity (Rated) ²		Heating Btu/h	459,000	459,000	486,000	486,000	513,000	513,000	
		Cooling Btu/h	390,000	390,000	415,000	415,000	435,000	435,000	
		High Temp Heating Btu/h	435,000	435,000	460,000	460,000	490,000	490,000	
AHRI - 1230 Efficiency Ratings ²		Low Temp Heating Btu/h	284,000	284,000	300,000	300,000	320,000	320,000	
		EER	-	9.80	9.80	9.60	9.60	9.70	9.70
		IEER	-	17.80	19.10	17.00	19.10	16.50	19.00
		COP@ 47°F	-	3.20	3.20	3.20	3.20	3.22	3.23
Power		COP@ 17°F	-	2.36	2.36	2.28	2.33	2.17	2.27
		SCHE	-	19.00	22.00	17.00	21.50	19.00	21.50
	MCA	A	Each individual outdoor unit requires a separate electrical connection. Refer to the electrical data for each individual outdoor unit.						
Compressor	MOP	A	SSC Scroll (5)						
	SCCR	KA	SSC Scroll (6)						
	Type (Qty.)	-	DS-GB052FAVBSSG x 3 + DS-GB066FAVBSSG x 2		DS-GB052FAVBSSG x 6		DS-GB052FAVBSSG x 4 + DS-GB066FAVBSSG x 1		
Oil	Type	-	PVE		PVE		PVE		
	Initial Charge	fl. oz.	551.1		628.8		551.1		

Table 25. 460 V heat recovery triple module: 34–38 ton capacity (continued)

Model Name		4TVR0408B400NC		4TVR0432B400NC		4TVR0456B400NC	
Individual Models		4TVR0072B400NB + 4TVR0144B400NB + 4TVR0192B400NC		3x 4TVR0144B400NB		4TVR0120B400NB + 2x 4TVR0168B400NC	
Power Supply		460/60/3		460/60/3		460/60/3	
Nominal Tons		34.0		36.0		38.0	
System Type		Ducted		Ducted		Ducted	
		Non-Ducted		Non-Ducted		Non-Ducted	
Fan	Type (Qty.)	Propeller (5)		Propeller (6)		Propeller (6)	
	Output (Each)	W		$(620 \times 2) + (620 \times 2)$		$(620 \times 2) + (620 \times 2) + (620 \times 2)$	
	Airflow Rate	CFM		7,240 + 9,535 + 10,950		9,180 + (10,950 x 2)	
	External Static Pressure	in. WG		0.31		0.31	
Piping Connections	Liquid Pipe	dia. in.		3/4 Braze		3/4 Braze	
	Gas Pipe	dia. in.		1-5/8 Braze		1-5/8 Braze	
	High Pressure Gas Pipe (for HR)	dia. in.		1-3/8 Braze		1-3/8 Braze	
	Installation Limits	Max Length ³	ft		656 (722)		656 (722)
Max Height ⁴		ft		361 (131)		361 (131)	
Indoor Unit Connections	Number of Connectable Indoor Units	-		64		64	
	Total Capacity (Cooling)	Btu/h		216,000 – 561,600		228,000 – 592,800	
Refrigerant	Type	-		R410A		R410A	
	Factory Charge	lbs.		55.6		64.8	
Sound ⁵	Sound Pressure	dB(A)		67		67	
	Sound Power	dB(A)		88		89	
External Dimensions	Net Weight	lbs.		430 + 672 + 750		637 + (732 x 2)	
	Shipping Weight	lbs.		465 + 714 + 788		679 + (770 x 2)	
	Net Dimensions (WxHxD)	in.		$(34.65 \times 66.73 \times 30.12) + (50.98 \times 66.73 \times 30.12) \times 2$		$(50.98 \times 66.73 \times 30.12) \times 3$	
	Shipping Dimensions (WxHxD)	in.		$37.32 \times 75.28 \times 32.76 + (53.66 \times 75.28 \times 32.76) \times 2$		$(53.66 \times 75.28 \times 32.76) \times 3$	

Table 25. 460 V heat recovery triple module: 34–38 ton capacity (continued)

Model Name		4TVR0408B400NC	4TVR0432B400NC	4TVR0456B400NC			
Individual Models		4TVR0072B400NB + 4TVR0144B400NB + 4TVR0192B400NC	3x 4TVR0144B400NB	4TVR0120B400NB + 2x 4TVR0168B400NC			
Power Supply		460/60/3					
Nominal Tons		38.0					
System Type	Operating Temp Range	34.0		36.0		38.0	
		Ducted	Non-Ducted	Ducted	Non-Ducted	Ducted	Non-Ducted
	Cooling ⁶	5 to 120		5 to 120		5 to 120	
	Heating	-13 to 75		-13 to 75		-13 to 75	

Notes:

- Nominal capacity based on 25 ft (7.6 m) of equivalent refrigerant piping with 0 ft level difference.
 - Cooling:** Indoor temperature 80°F DB, 67°F WB/Outdoor temperature 95°F DB, 75°F WB
 - Heating:** Indoor temperature 70°F DB, 60°F WB/Outdoor temperature 47°F DB, 43°F WB
- Rated per AHRI-1230 Standard conditions.
- Actual length (equivalent length in parenthesis).
- If the outdoor unit is installed above the indoor unit, the allowable height difference is 361 ft (110 m). If the outdoor unit is installed below the indoor unit, the allowable height difference is 131 ft (40 m).
- Sound pressure was acquired in a dead room. Actual noise level may be different depending on installation conditions.
- Refer to the "Outdoor Unit Operation Limits" section of this document.
- Requires two each 4TDK3819B0000A and 4TDK3100B0000A outdoor unit Y-joint connections.

Table 26. 460 V heat recovery triple module: 40–44 ton capacity

Model Name	4TVR0480B400NC		4TVR0504B400NC		4TVR0528B400NC				
Individual Models	4TVR0144B400NB + 2x 4TVR0168B400NC		3x 4TVR0168B400NC		2x 4TVR0168B400NC + 4TVR0192B400NC				
Power Supply	460/60/3		460/60/3		460/60/3				
Nominal Tons	40.0		42.0		44.0				
System Type	Ducted		Non-Ducted		Ducted		Non-Ducted		
	Performance	Capacity (Nominal) ¹	Btu/h	480,000	480,000	504,000	504,000	528,000	528,000
Capacity (Rated) ²		Heating	540,000	540,000	567,000	567,000	594,000	594,000	
		Cooling	455,000	455,000	480,000	480,000	500,000	500,000	
High Temp Heating		Btu/h	510,000	510,000	535,000	535,000	560,000	560,000	
		Low Temp Heating	Btu/h	332,000	332,000	348,000	348,000	364,000	364,000
AHRI -1230 Efficiency Ratings ²		EER	-	9.60	9.60	9.60	9.60	9.50	9.50
		IEER	-	16.60	18.60	16.40	18.40	16.00	18.00
		COP @ 47°F	-	3.21	3.21	3.21	3.21	3.20	3.20
		COP @ 17°F	-	2.13	2.23	2.11	2.21	2.10	2.05
		SCHE	-	19.00	21.50	19.00	20.00	18.50	19.00
Power	MCA	A	Each individual outdoor unit requires a separate electrical connection. Refer to the electrical data for each individual outdoor unit.						
	MOP	A							
	SCCR	kA							
Compressor	Type (Qty.)	-	SSC Scroll (6)		SSC Scroll (6)		SSC Scroll (6)		
	Model Name	-	DS-GB052FAVBSG x 6		DS-GB052FAVBSG x 6		DS-GB052FAVBSG x 4 + DS-GB066FAVBSG x 2		
	Oil	fl. oz.	628.8		628.8		628.8		

Product Specifications
Table 26. 460 V heat recovery triple module: 40–44 ton capacity (continued)

Model Name	4TVR0480B400NC		4TVR0504B400NC		4TVR0528B400NC	
Individual Models	4TVR0144B400NB + 2x 4TVR0168B400NC		3x 4TVR0168B400NC		2x 4TVR0168B400NC + 4TVR0192B400NC	
Power Supply	460/60/3		460/60/3		460/60/3	
Nominal Tons	40.0		42.0		44.0	
System Type	Ducted	Non-Ducted	Ducted	Non-Ducted	Ducted	Non-Ducted
Fan	Type (Qty.)	-	Propeller (6)		Propeller (6)	
	Output (Each)	W	(620 x 2) + (620 x 2) + (620 X 2)		(620 x 2) + (620 x 2) + (620 X 2)	
	Airflow Rate	CFM	9,535 + (10,950 x 2)		10,950 x 3	
	External Static Pressure	in. WG	0.31		0.31	
	Liquid Pipe	dia. in.	3/4 Braze		3/4 Braze	
Piping Connections	Gas Pipe	dia. in.	1-5/8 Braze		1-5/8 Braze	
	High Pressure Gas Pipe (for HR)	dia. in.	1-3/8 Braze		1-3/8 Braze	
	Installation Limits	Max Length ³	656 (722)		656 (722)	
		Max Height ⁴	361 (131)		361 (131)	
	Number of Connectable Indoor Units	-	64		64	
Total Capacity (Cooling)	Btu/h	240,000 – 624,000		252,000 – 655,200		
Refrigerant	Type	-	R410A		R410A	
	Factory Charge	lbs.	67.7		72.8	
Sound ⁵	Sound Pressure	dB(A)	67		68	
	Sound Power	dB(A)	89		90	
	Net Weight	lbs.	672 + (732 x 2)		(732 x 2) + 750	
External Dimensions	Shipping Weight	lbs.	714 + (770 x 2)		(770 x 2) + 788	
	Net Dimensions (WxHxD)	in.	(50.98 x 66.73 x 30.12) x 3		(50.98 x 66.73 x 30.12) x 3	
	Shipping Dimensions (WxHxD)	in.	(53.66 x 75.28 x 32.76) x 3		(53.66 x 75.28 x 32.76) x 3	

Table 26. 460 V heat recovery triple module: 40–44 ton capacity (continued)

Model Name		4TVR0480B400NC	4TVR0504B400NC	4TVR0528B400NC	
Individual Models		4TVR0144B400NB + 2x 4TVR0168B400NC	3x 4TVR0168B400NC	2x 4TVR0168B400NC + 4TVR0192B400NC	
Power Supply		460/60/3	460/60/3	460/60/3	
Nominal Tons		40.0	42.0	44.0	
System Type		Ducted	Non-Ducted	Ducted	Non-Ducted
Operating Temp Range	Cooling ⁶	5 to 120 °F	5 to 120	5 to 120	5 to 120
	Heating	-13 to 75 °F	-13 to 75	-13 to 75	-13 to 75

Notes:

- Nominal capacity based on 25 ft (7.6 m) of equivalent refrigerant piping with 0 ft level difference.
 - Cooling:** Indoor temperature 80°F DB, 67°F WB/Outdoor temperature 95°F DB, 75°F WB
 - Heating:** Indoor temperature 70°F DB, 60°F WB/Outdoor temperature 47°F DB, 43°F WB
- Rated per AHRI-1230 Standard conditions.
- Actual length (equivalent length in parenthesis).
- If the outdoor unit is installed above the indoor unit, the allowable height difference is 361 ft (110 m). If the outdoor unit is installed below the indoor unit, the allowable height difference is 131 ft (131 m).
- Sound pressure was acquired in a dead room. Actual noise level may be different depending on installation conditions.
- Refer to the "Outdoor Unit Operation Limits" section of this document.
- Requires two each 4TDK3819B0000A and 4TDK3100B0000A outdoor unit Y-joint connections.

Outdoor Unit Operation Limits

Notes:

- For Figure 1, p. 82 and Figure 2, p. 82, it is recommended that a wind/snow prevention duct be used for outdoor units that produce cooling or heating below an ambient temperature of 23°F (-5°C).
- For Figure 1, p. 82:
 - Expanded operational temperature range applies to heat recovery systems. Cooling operation between 23°F (-5°C) and 5°F (-15°C) requires twin porting of the applicable indoor units (18 MBH indoor units and above).
 - Technical cooling applies only to heat recovery systems. Technical cooling requires that the system be operating in heating mode with heating demand equal or greater than cooling demand.

Figure 1. Cooling

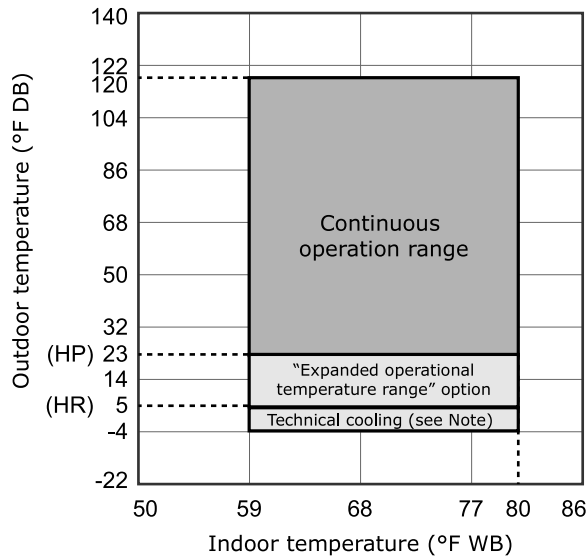
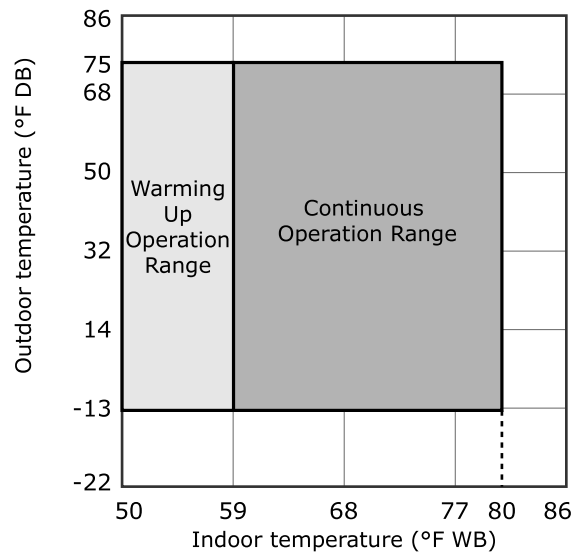

Figure 2. Heating



Defrosting Correction Factor

In heating operation, frost can be formed on heat exchanger according to outdoor temperature. (frost on heat exchanger results in decreasing the performance.) To remove frost on heat exchanger of outdoor unit, defrost operation is carried out periodically. During defrost operation, capacity of outdoor unit may decrease. The decrement is not considered to the individual capacity tables.

Outdoor temperature (°F, WB)	14.0	17.6	21.2	24.8	28.4	32.0	37.4	41.0	44.6
Capacity coefficient	0.98	0.97	0.95	0.93	0.88	0.85	0.86	0.91	1.00

Figure 3. Corrected Heating Capacity – Heating Capacity x Capacity Coefficient

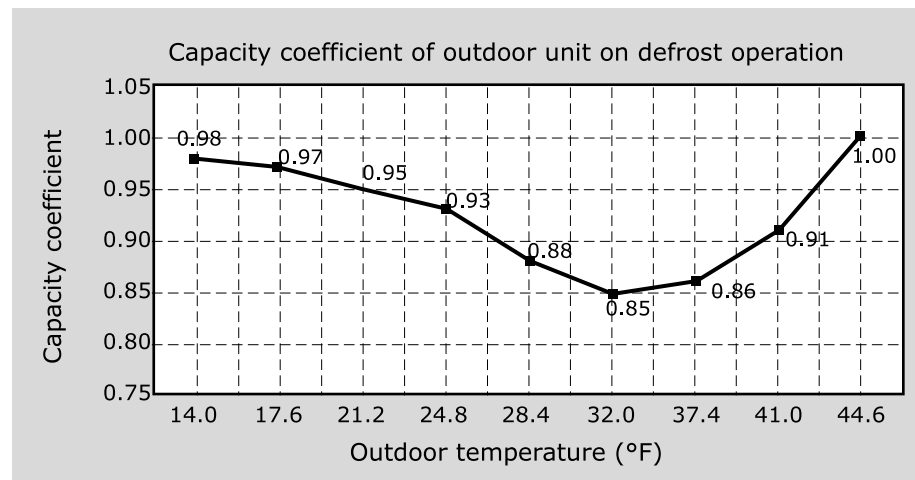



Electrical Wiring Diagrams – Outdoor Units

Figure 4. Heat Pump - 4TVH0072B300NB, 4TVH0072B400NB

Note 1: Resistance value at 25°C (77°F)

Note 2: Input voltage 460 V: Does not apply
Input voltage 208–230 V: Apply

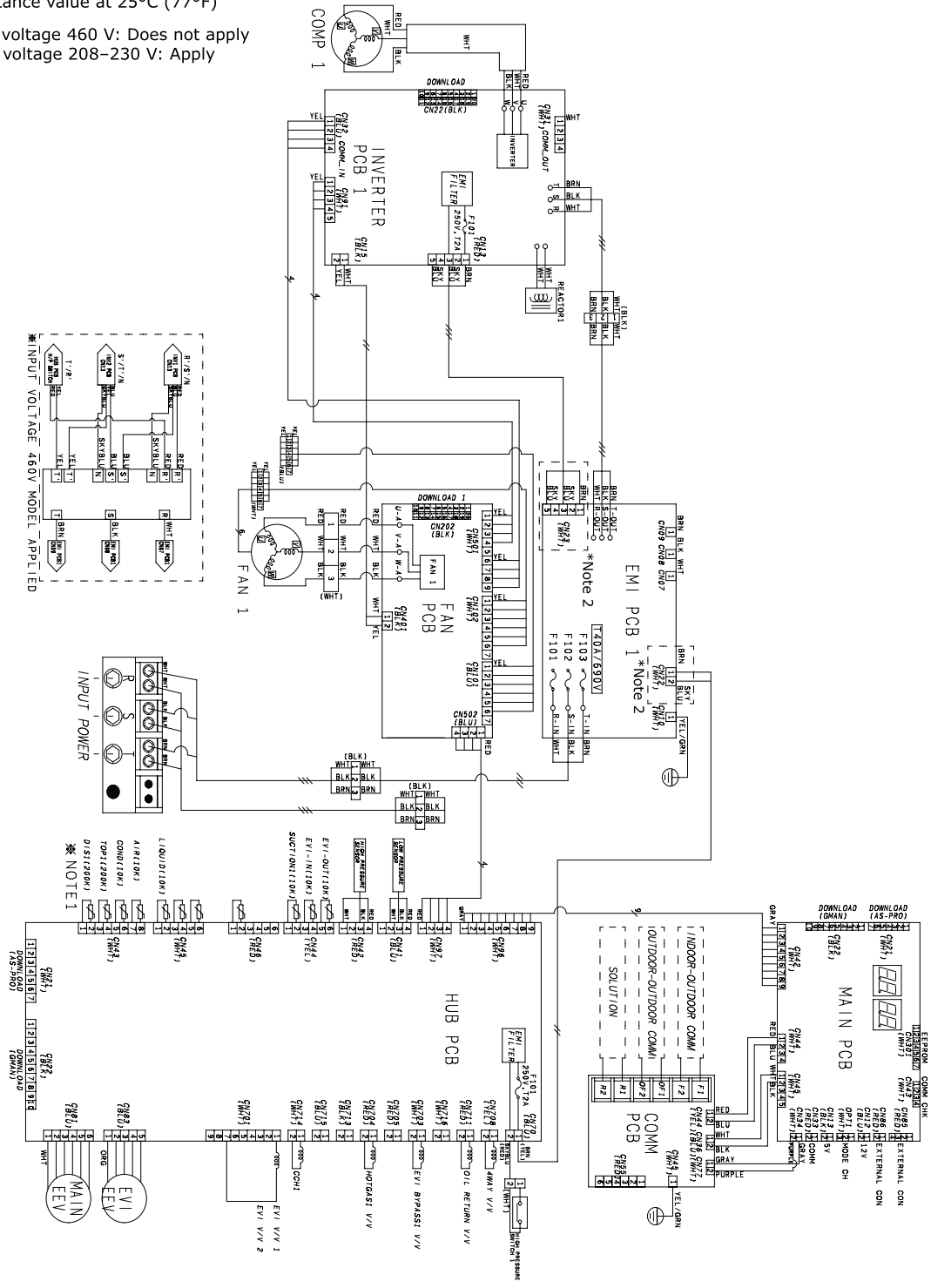
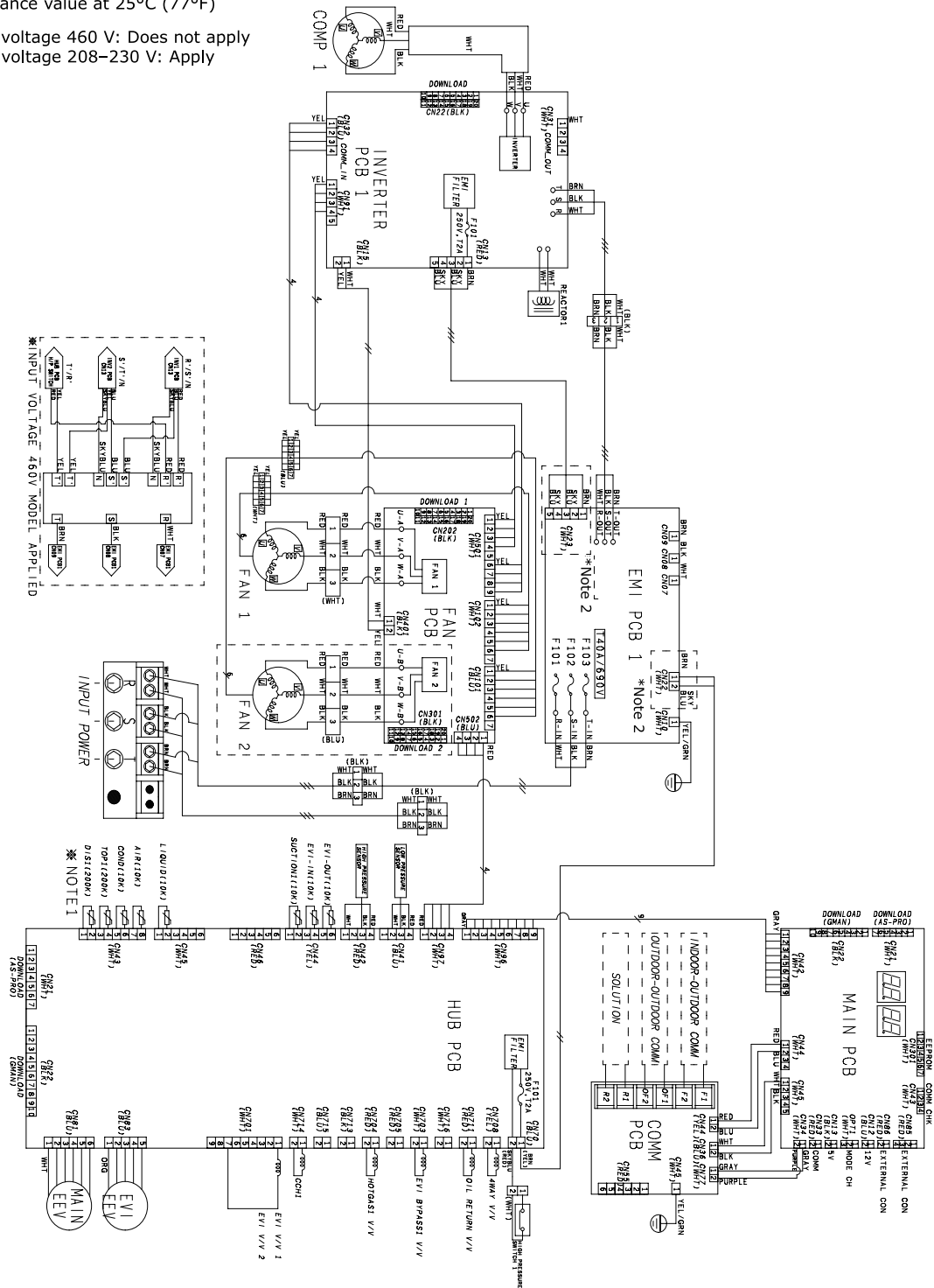

Figure 5. Heat Pump - 4TVH0096B400NB, 4TVH0120B400NB

Note 1: Resistance value at 25°C (77°F)

Note 2: Input voltage 460 V: Does not apply
Input voltage 208–230 V: Apply



Electrical Wiring Diagrams – Outdoor Units

Figure 6. Heat Pump - 4TVH0096B300NB, 4TVH0120B300NB, 4TVH0144B300NB, 4TVH0144B400NB, 4TVH0168B300NC, 4TVH0168B400NC, 4TVH0192B300NC, and 4TVH0192B400NC

Note 1: Resistance value at 25°C (77°F)

Note 2: Input voltage 460 V: Does not apply
Input voltage 208–230 V: Apply

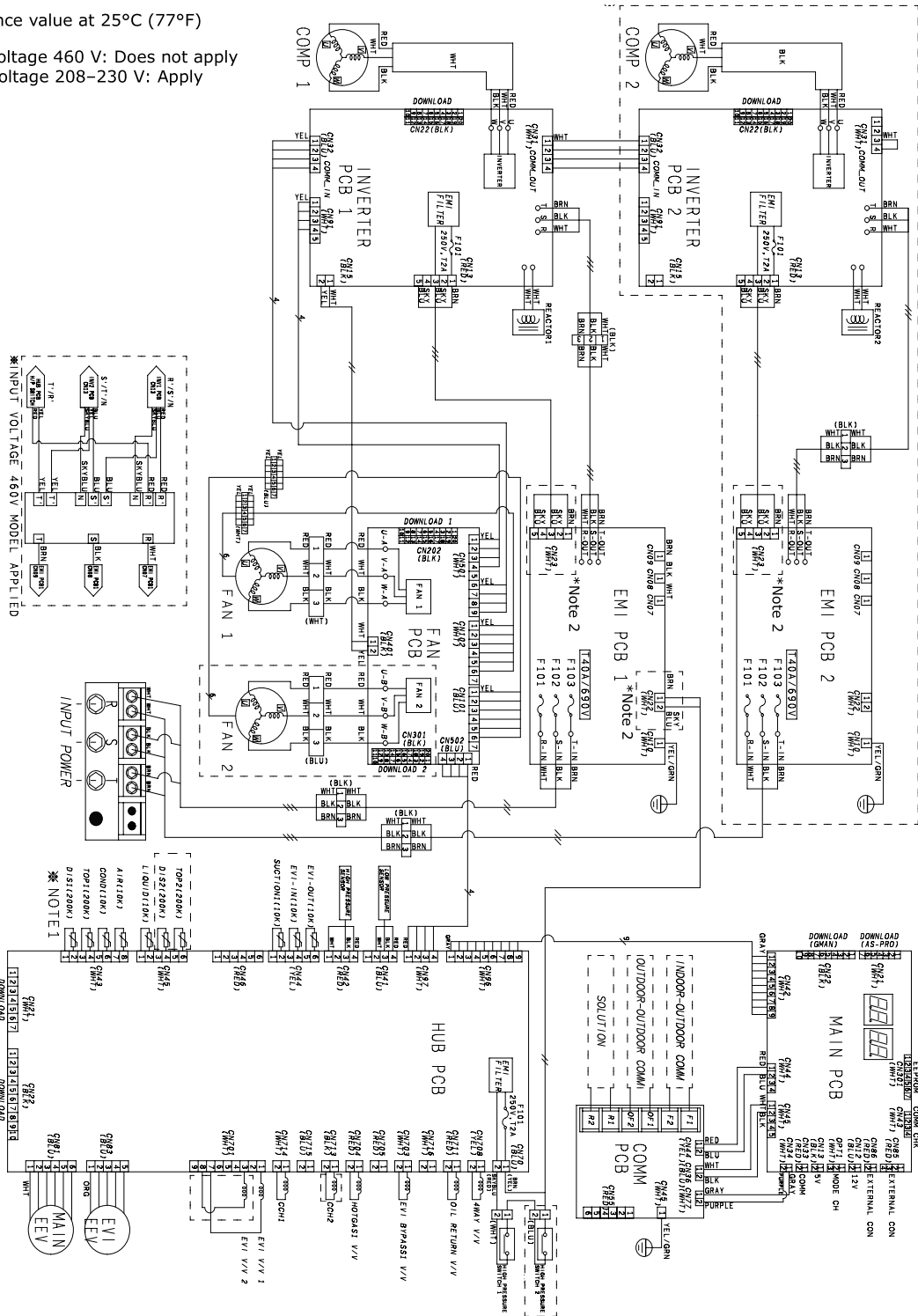

Figure 7. Heat Recovery - 4TVR0072B300NB, 4TVR0072B400NB

Note 1: Resistance value at 25°C (77°F)

Note 2: Input voltage 460 V: Does not apply
Input voltage 208–230 V: Apply

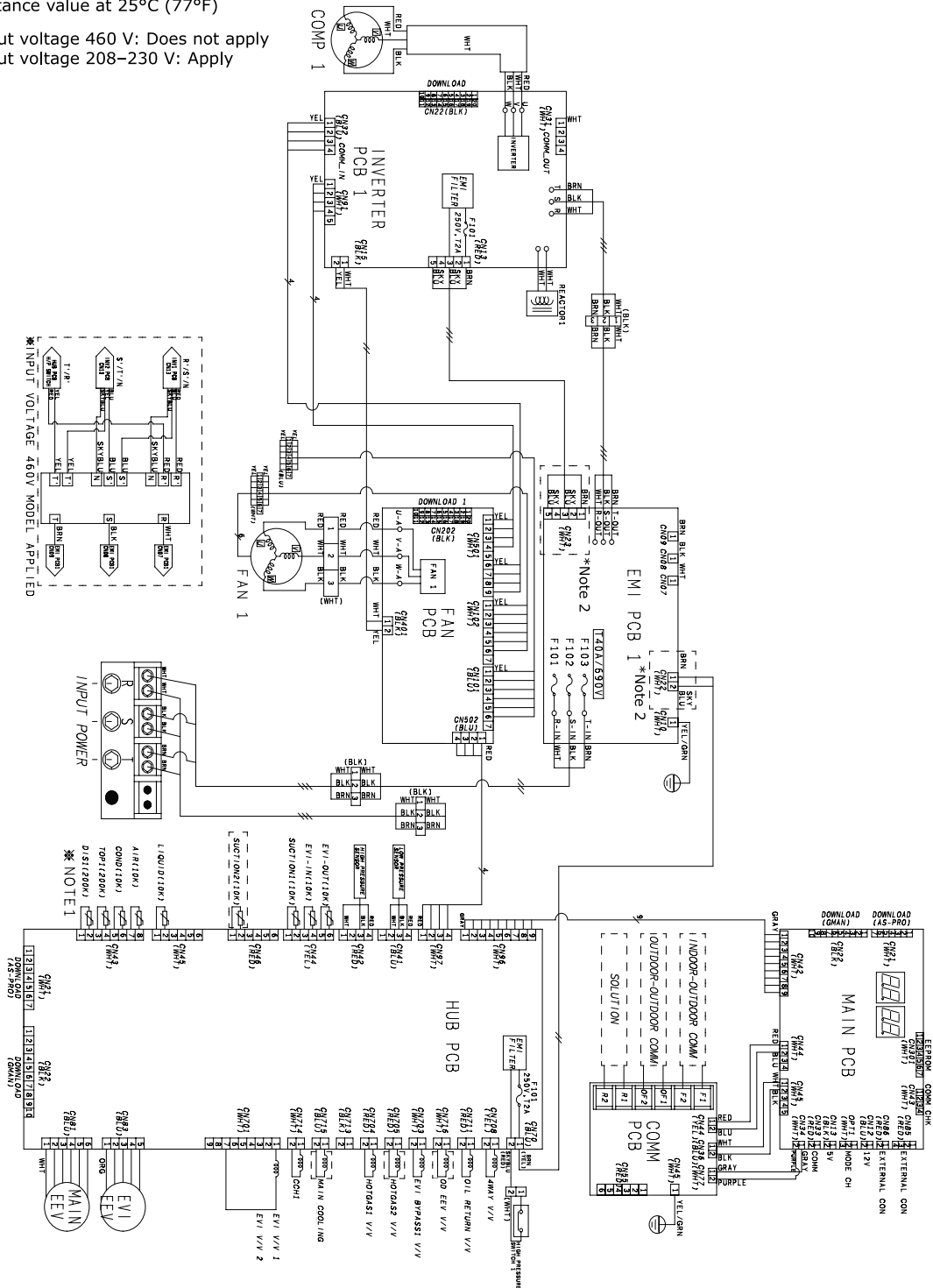
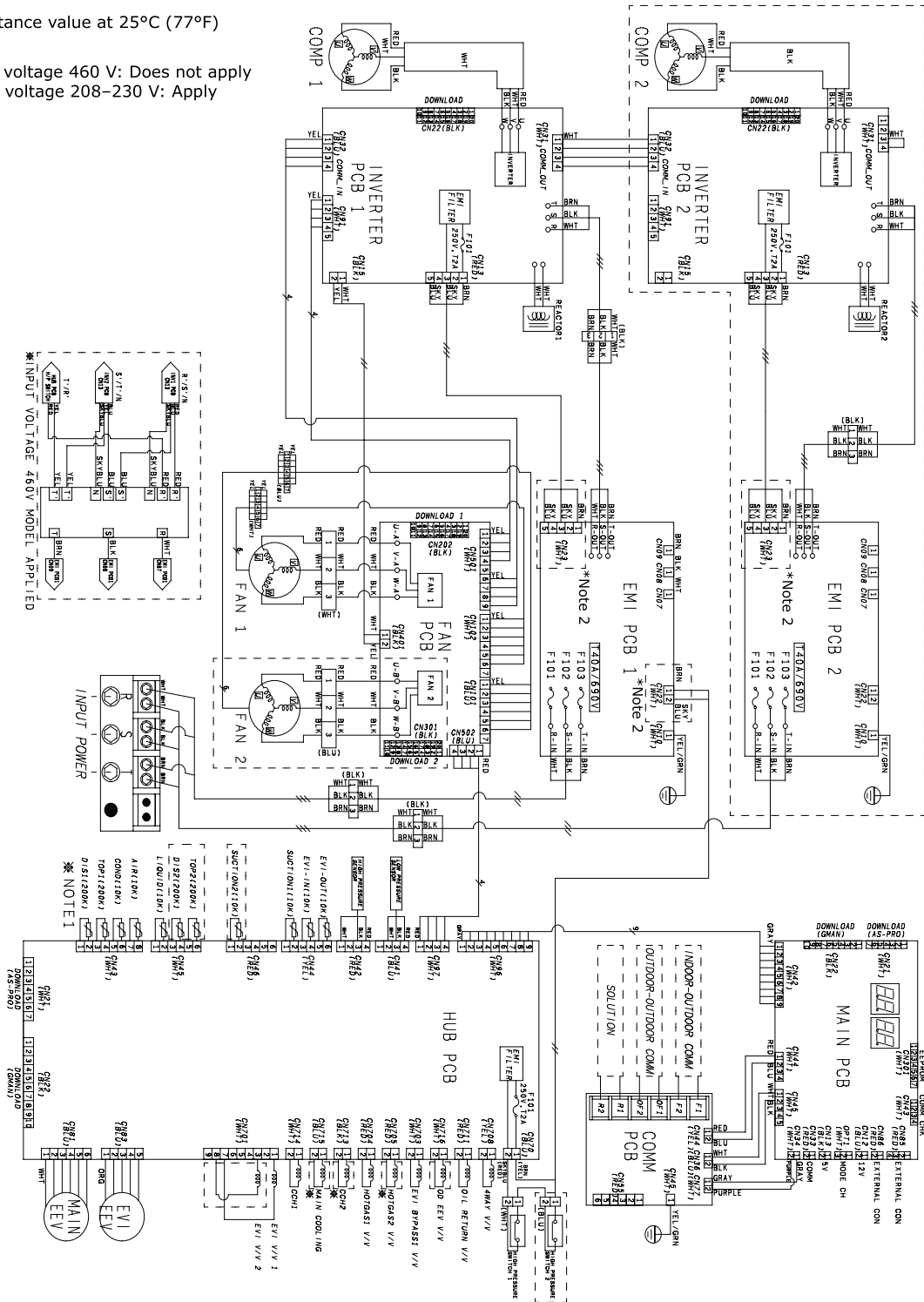

Figure 9. Heat Recovery - 4TVR0096B300NB, 4TVR0120B300NB, 4TVR0144B300NB, 4TVR0144B400NB, 4TVR0168B300NC, 4TVR0168B400NC, 4TVR0192B300NC and 4TVR0192B400NC

Note 1: Resistance value at 25°C (77°F)

Note 2: Input voltage 460 V: Does not apply
Input voltage 208–230 V: Apply



Sound Levels

Sound Pressure Level

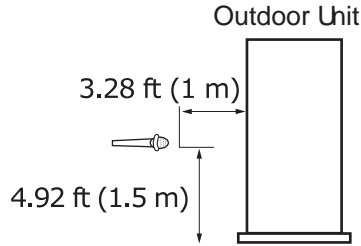

Model	Pressure, Unit: dB(A)
4TVH/R0072B3, 4TVH/R0072B4	60
4TVH/R0096B3, 4TVH/R0096B4	61
4TVH/R0120B3, 4TVH/R0120B4	61
4TVH/R0144B3, 4TVH/R0144B4	62
4TVH/R0168B3, 4TVH/R0168B4	63
4TVH/R0192B3, 4TVH/R0192B4	64

Notes:

- *Measuring place: Anechoic chamber (conversion value)*
- *These operation sound value were obtained in a anechoic room. Sound pressure level will vary depending on a range of factors such as the construction of the particular room where the equipment is installed.*
- *Operation sound level may differ depending on operation and ambient conditions.*

NC Curves

4TVH/R0072B3, 4TVH/R0072B4

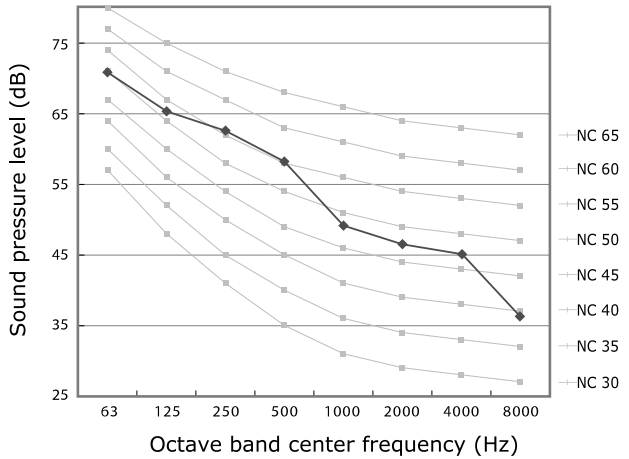

4TVH/R0096B3, 4TVH/R0096B4

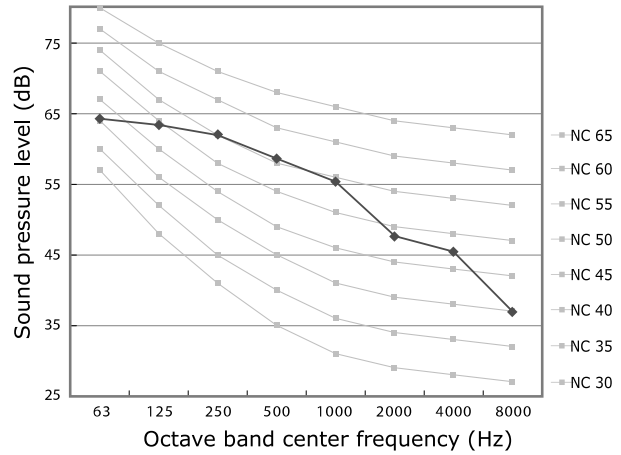

4TVH/R0120B3, 4TVH/R0120B4

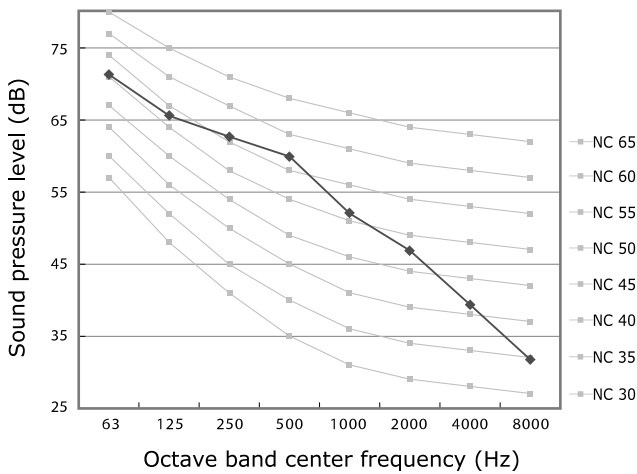

4TVH/R0144B3, 4TVH/R0144B4

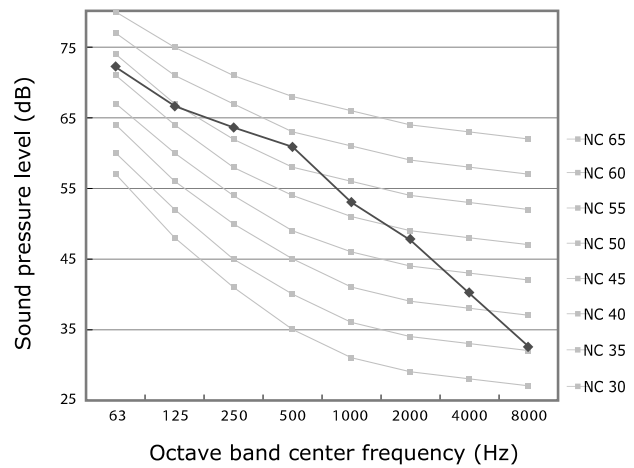

4TVH/R0168B3, 4TVH/R0168B4

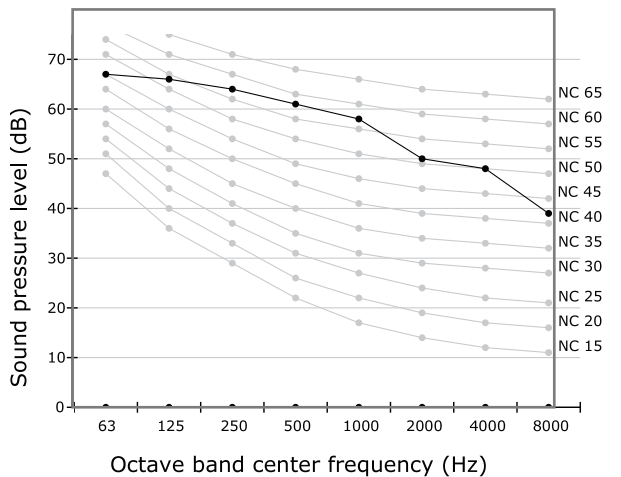

4TVH/R0192B3, 4TVH/R0192B4

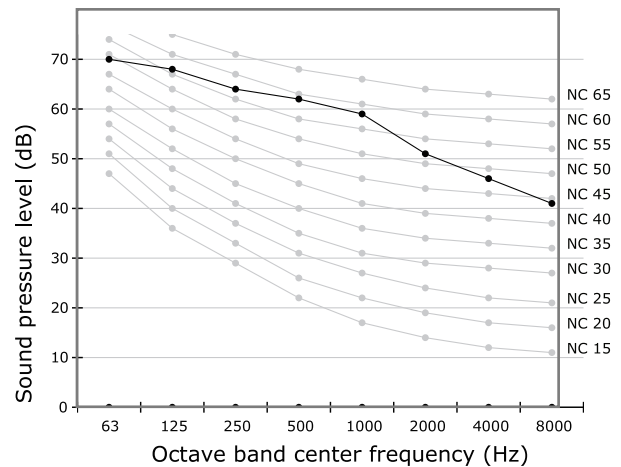



Sound Power

Notes:

- *dBA = A-weighted sound power level.*
- *Reference power: 1 pW*
- *Measured according to ISO 3741.*

Model	Power, Unit: dB(A)
4TVH/R0072B3, 4TVH/R0072B4	77
4TVH/R0096B3, 4TVH/R0120B3	81
4TVH/R0120B3, 4TVH/R0120B4	81
4TVH/R0144B3, 4TVH/R0144B4	83
4TVH/R0168B3, 4TVH/R0168B4	85
4TVH/R0192B3, 4TVH/R0192B4	86

NR Curves

4TVH/R0072B3, 4TVH/R0072B4

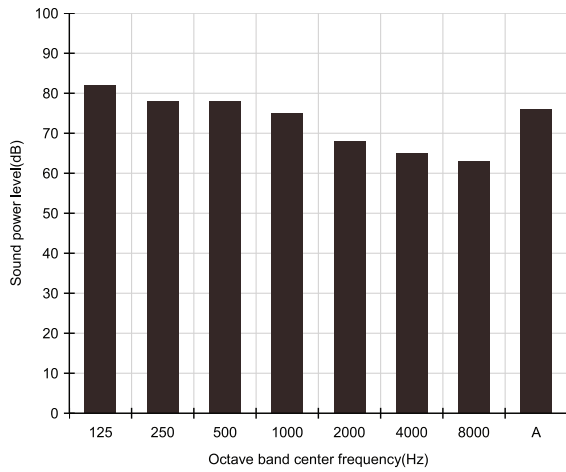

4TVH/R0096B3, 4TVH/R0096B4

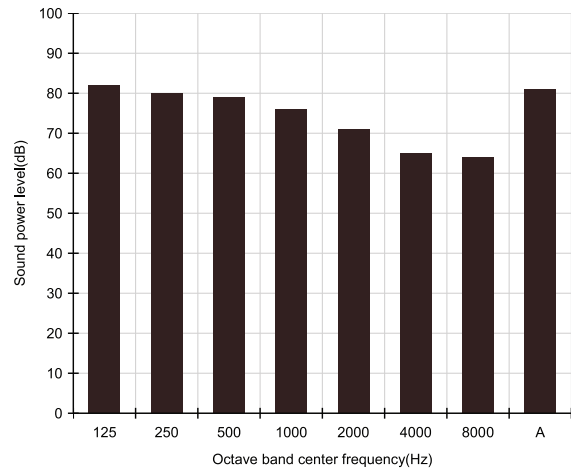

4TVH/R0120B3, 4TVH/R0120B4

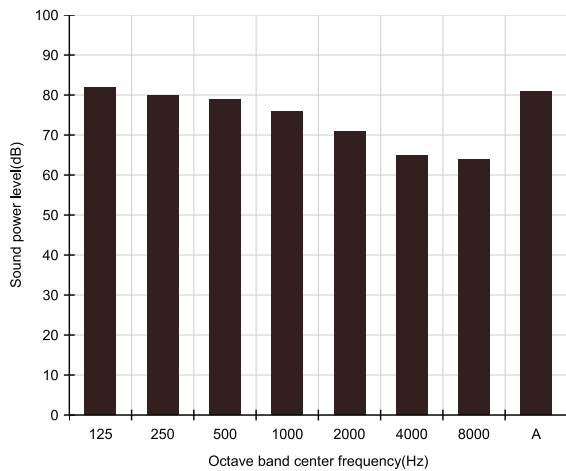

4TVH/R0144B3, 4TVH/R0144B4

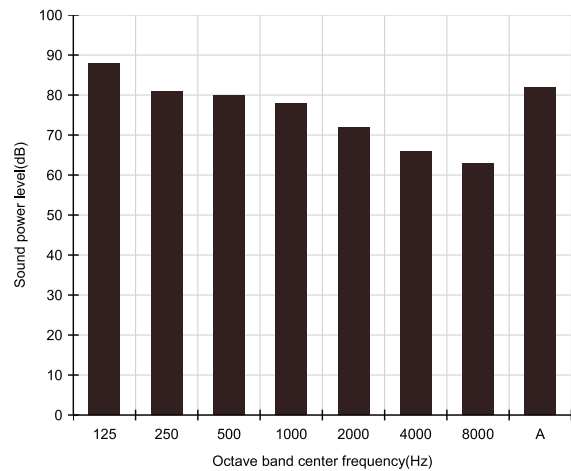

4TVH/R0168B3, 4TVH/R0168B4

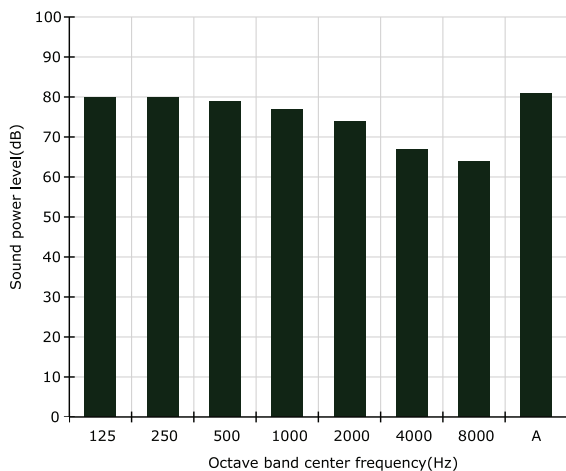

4TVH/R0192B3, 4TVH/R0192B4

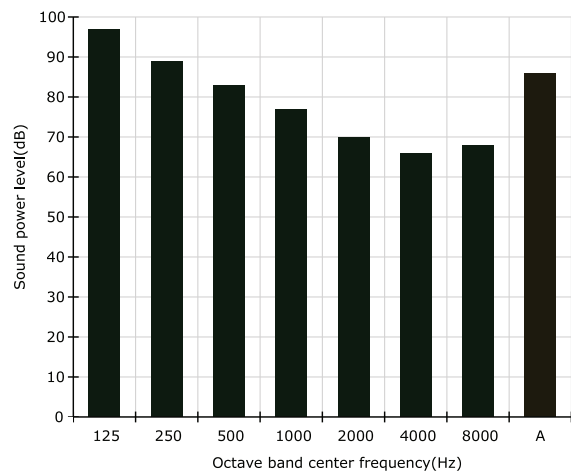

Refrigerant Cycle Diagrams

Parts of Outdoor Unit (HP)

Figure 10. Refrigerant Cycle Diagram 4TVH0072B300NB and 4TVH0072B400NB

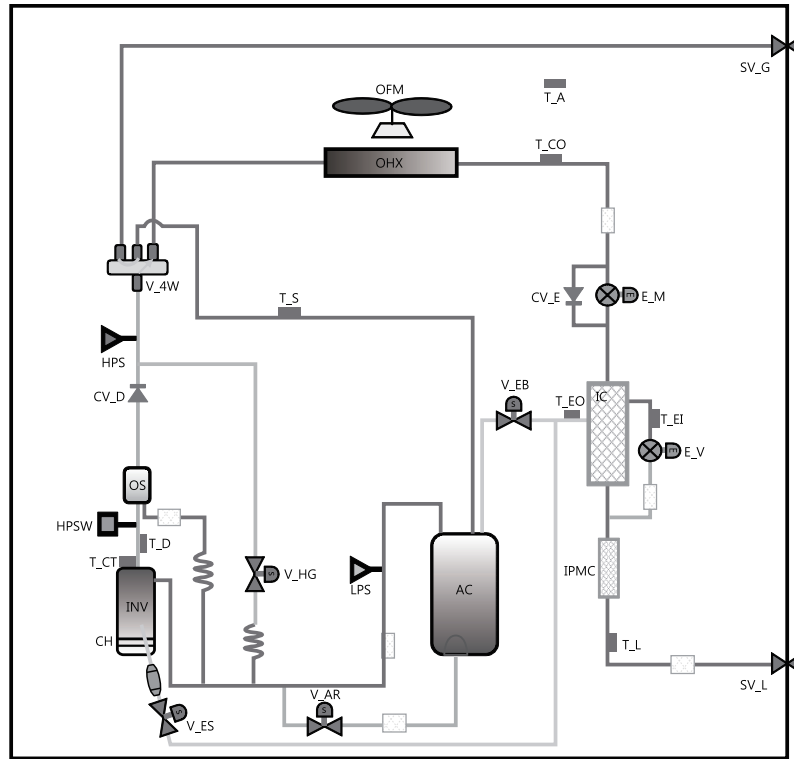

Classification	Description
INV	Inverter Compressor
OFM	Outdoor Fan Motor
OHX	Outdoor Heat Exchanger
AC	Accumulator
OS	Oil Separator
IC	Intercooler
IPMC	IPM Cooler
CH	Crank Case Heater
HPS	High Pressure Sensor
LPS	Low Pressure Sensor
HPSW	High Pressure Switch
E_M	Main EEV
E_EV	EVI EEV
V_ES	EVI Solenoid Valve
V_EB	EVI Bypass Valve

Classification	Description
V_HG	Hot Gas Bypass Valve
V_4W	4way Valve
V_AR	Accumulator Oil Return Valve
CV_E	EEV Bypass Check Valve
CV_D	Discharge Check Valve
T_D	Discharge Temperature Sensor
T_S	Suction Temperature Sensor
T_CO	Condenser Out Temperature Sensor
T_EI	EVI In Temperature Sensor
T_EO	EVI Out Temperature Sensor
T_L	Liquid Tube Temperature Sensor
T_CT	Compressor Top Temperature Sensor
T_A	Ambient Temperature Sensor
SV_G	Gas Pipe Service Valve
SV_L	Liquid Pipe Service Valve

Figure 11. Refrigerant Cycle Diagram 4TVH0096B400NB and 4TVH0120B400NB

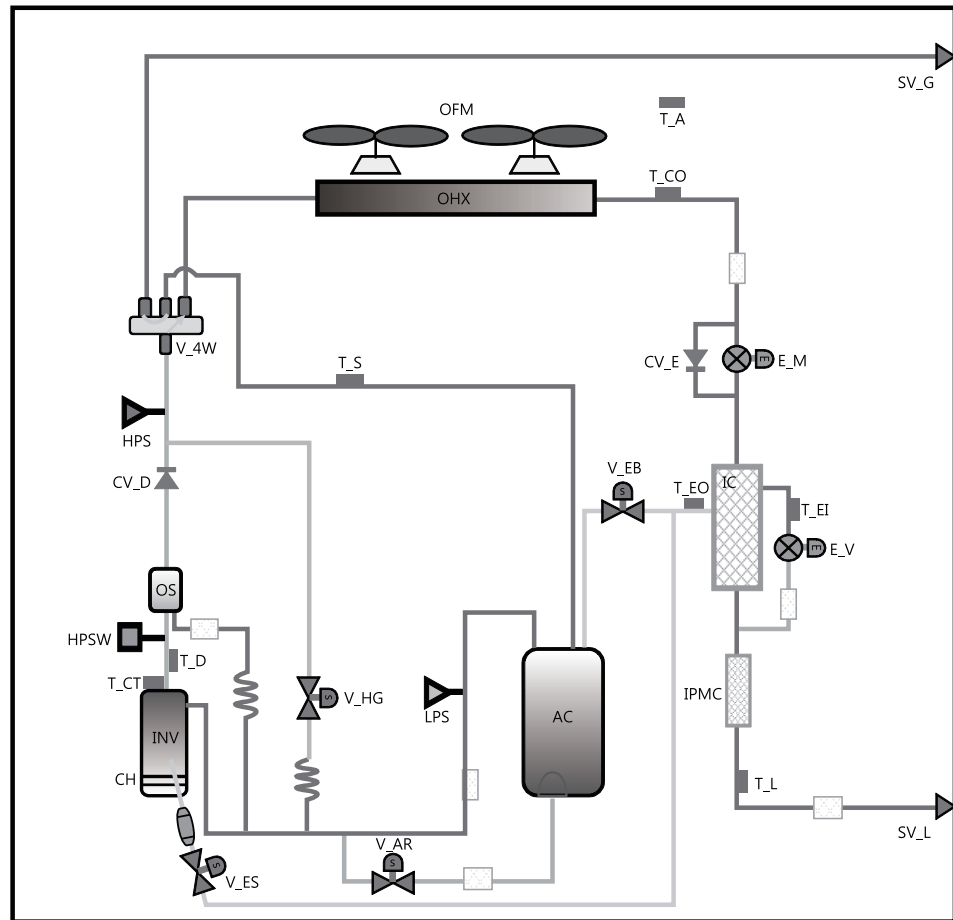

Classification	Description
INV	Inverter Compressor
OFM	Outdoor Fan Motor
OHX	Outdoor Heat Exchanger
AC	Accumulator
OS	Oil Separator
IC	Intercooler
IPMC	IPM Cooler
CH	Crank Case Heater
HPS	High Pressure Sensor
LPS	Low Pressure Sensor
HPSW	High Pressure Switch
E_M	Main EEV
E_EV	EVI EEV
V_ES	EVI Solenoid Valve
V_EB	EVI Bypass Valve

Classification	Description
V_HG	Hot Gas Bypass Valve
V_4W	4way Valve
V_AR	Accumulator Oil Return Valve
CV_E	EEV Bypass Check Valve
CV_D	Discharge Check Valve
T_D	Discharge Temperature Sensor
T_S	Suction Temperature Sensor
T_CO	Condenser Out Temperature Sensor
T_EI	EVI In Temperature Sensor
T_EO	EVI Out Temperature Sensor
T_L	Liquid Tube Temperature Sensor
T_CT	Compressor Top Temperature Sensor
T_A	Ambient Temperature Sensor
SV_G	Gas Pipe Service Valve
SV_L	Liquid Pipe Service Valve

Figure 12. Refrigerant Cycle Diagram 4TVH0096B300NB, 4TVH0120B300NB, 4TVH0144B300NB, 4TVH0144B400NB, 4TVH0168B300NC, 4TVH0168B400NC, 4TVH0192B300NC and 4TVH0192B400NC

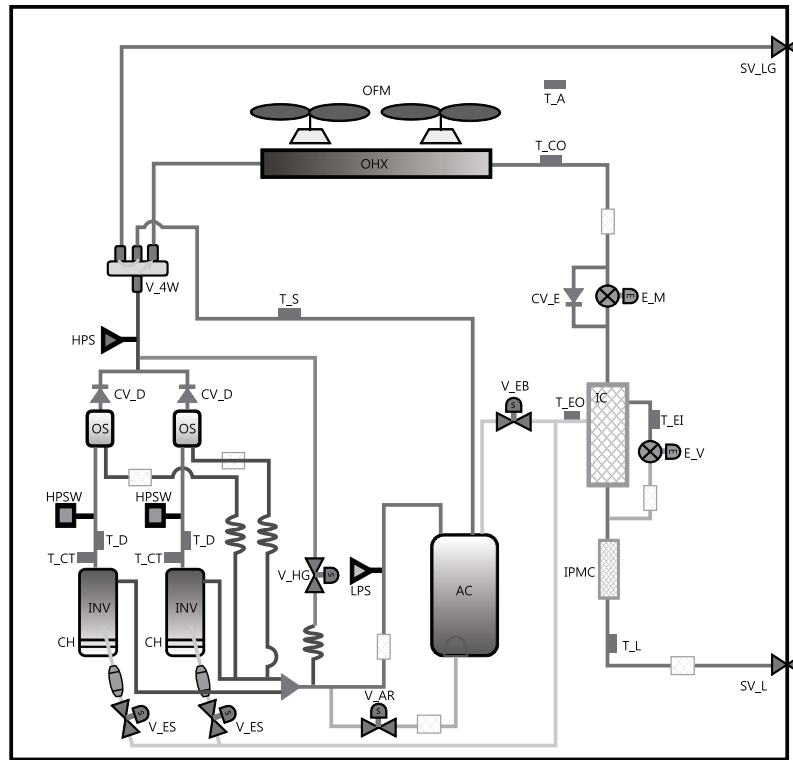

Classification	Description
INV	Inverter Compressor
OFM	Outdoor Fan Motor
OHX	Outdoor Heat Exchanger
AC	Accumulator
OS	Oil Separator
IC	Intercooler
IPMC	IPM Cooler
CH	Crank Case Heater
HPS	High Pressure Sensor
LPS	Low Pressure Sensor
HPSW	High Pressure Switch
E_M	Main EEV
E_EV	EVI EEV
V_ES	EVI Solenoid Valve
V_EB	EVI Bypass Valve

Classification	Description
V_HG	Hot Gas Bypass Valve
V_4W	4way Valve
V_AR	Accumulator Oil Return Valve
CV_E	EEV Bypass Check Valve
CV_D	Discharge Check Valve
T_D	Discharge Temperature Sensor
T_S	Suction Temperature Sensor
T_CO	Condenser Out Temperature Sensor
T_EI	EVI In Temperature Sensor
T_EO	EVI Out Temperature Sensor
T_L	Liquid Tube Temperature Sensor
T_CT	Compressor Top Temperature Sensor
T_A	Ambient Temperature Sensor
SV_G	Gas Pipe Service Valve
SV_L	Liquid Pipe Service Valve

Parts of Outdoor Unit (HR)

Figure 13. Refrigerant Cycle Diagram 4TVR0072B300NB, 4TVR0072B400NB

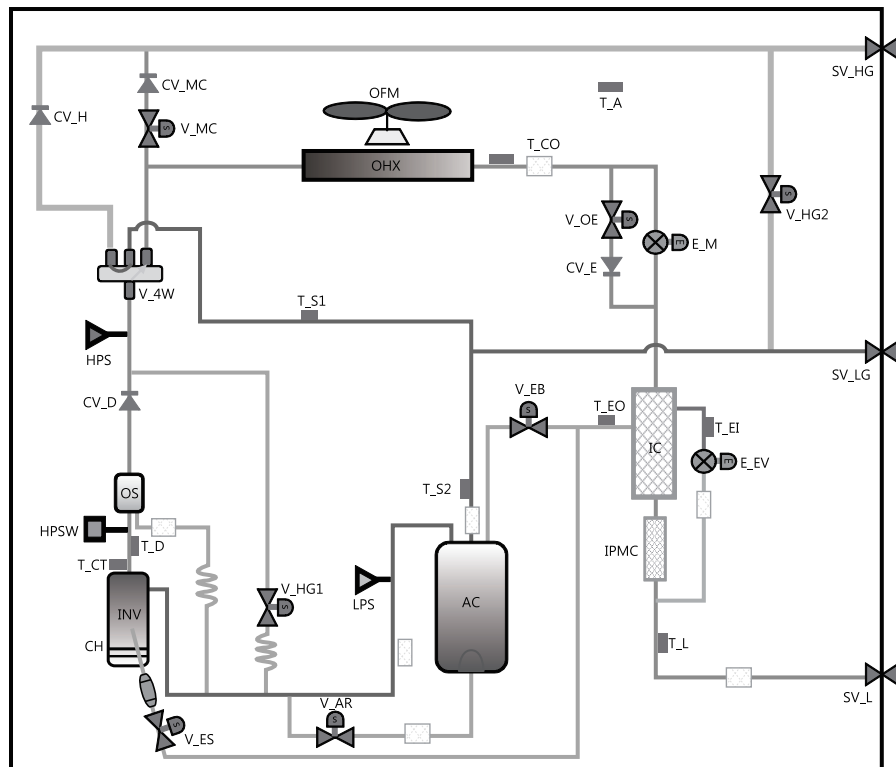

Classification	Description
INV	Inverter Compressor
OFM	Outdoor Fan Motor
OHX	Outdoor Heat Exchanger
AC	Accumulator
OS	Oil Separator
IC	Intercooler
IPMC	IPM Cooler
CH	Crank Case Heater
HPS	High Pressure Sensor
LPS	Low Pressure Sensor
HPSW	High Pressure Switch
E_M	Main EEV
E_EV	EVI EEV
V_ES	EVI Solenoid Valve
V_EB	EVI Bypass Valve

Classification	Description
V_HG	Hot Gas Bypass Valve
V_4W	4way Valve
V_AR	Accumulator Oil Return Valve
CV_E	EEV Bypass Check Valve
CV_D	Discharge Check Valve
T_D	Discharge Temperature Sensor
T_S	Suction Temperature Sensor
T_CO	Condenser Out Temperature Sensor
T_EI	EVI In Temperature Sensor
T_EO	EVI Out Temperature Sensor
T_L	Liquid Tube Temperature Sensor
T_CT	Compressor Top Temperature Sensor
T_A	Ambient Temperature Sensor
SV_LG	Low Pressure Gas Pipe Service Valve
SV_L	Liquid Pipe Service Valve
SV_HG	High Pressure Gas Pipe Service Valve

Figure 14. Refrigerant Cycle Diagram 4TVR0096B400NB and 4TVR0120B400NB

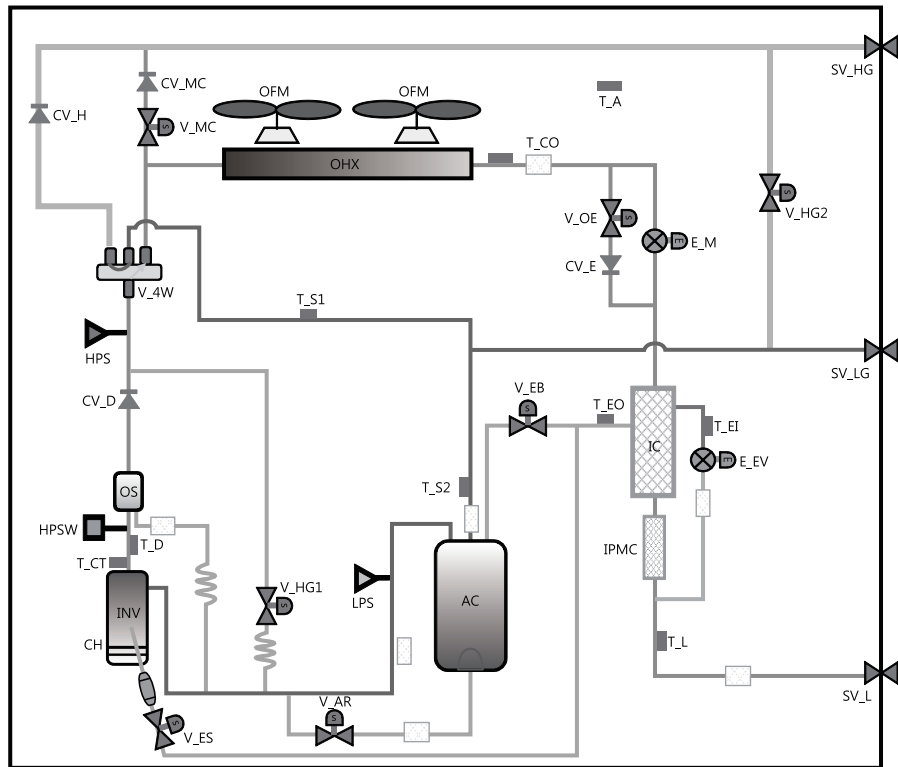

Classification	Description
INV	Inverter Compressor
OFM	Outdoor Fan Motor
OHX	Outdoor Heat Exchanger
AC	Accumulator
OS	Oil Separator
IC	Intercooler
IPMC	IPM Cooler
CH	Crank Case Heater
HPS	High Pressure Sensor
LPS	Low Pressure Sensor
HPSW	High Pressure Switch
E_M	Main EEV
E_EV	EVI EEV
V_ES	EVI Solenoid Valve
V_EB	EVI Bypass Valve

Classification	Description
V_HG	Hot Gas Bypass Valve
V_4W	4way Valve
V_AR	Accumulator Oil Return Valve
CV_E	EEV Bypass Check Valve
CV_D	Discharge Check Valve
T_D	Discharge Temperature Sensor
T_S	Suction Temperature Sensor
T_CO	Condenser Out Temperature Sensor
T_EI	EVI In Temperature Sensor
T_EO	EVI Out Temperature Sensor
T_L	Liquid Tube Temperature Sensor
T_CT	Compressor Top Temperature Sensor
T_A	Ambient Temperature Sensor
SV_LG	Low Pressure Gas Pipe Service Valve
SV_L	Liquid Pipe Service Valve
SV_HG	High Pressure Gas Pipe Service Valve

Figure 15. Refrigerant Cycle Diagram 4TVR0096B300NB, 4TVR0120B300NB, 4TVR0144B300NB, 4TVR0144B400NB, 4TVR0168B300NC, 4TVR0168B400NC, 4TVR0192B300NC and 4TVR0192B400NC

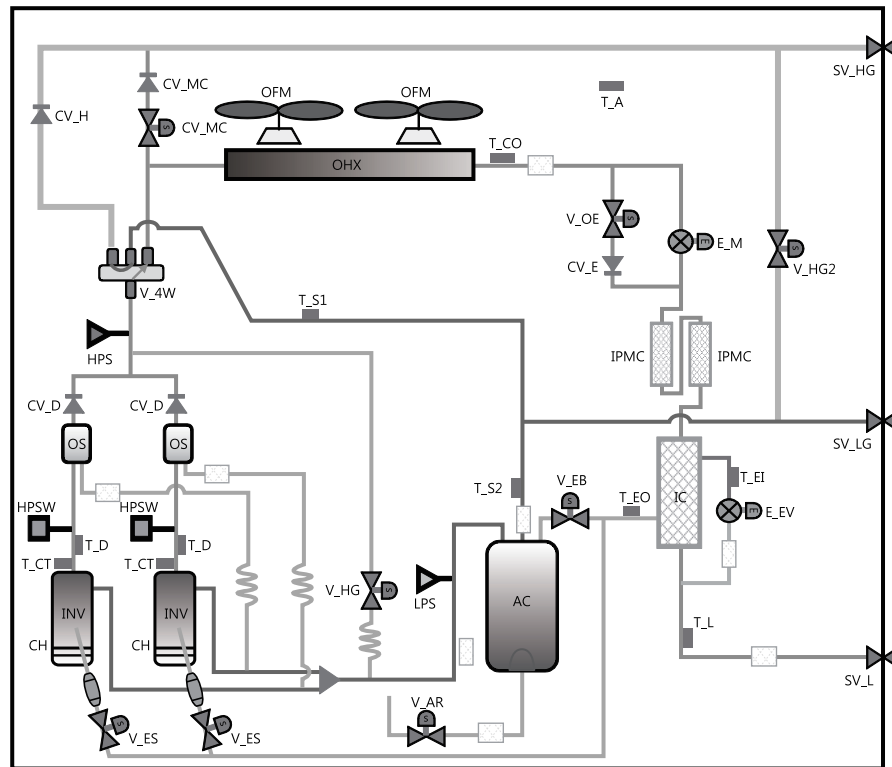

Classification	Description
INV	Inverter Compressor
OFM	Outdoor Fan Motor
OHX	Outdoor Heat Exchanger
AC	Accumulator
OS	Oil Separator
IPMC	IPM Cooler
CH	Crank Case Heater
HPS	High Pressure Sensor
LPS	Low Pressure Sensor
HPSW	High Pressure Switch
E_M	Main EEV
E_EV	EVI EEV
V_ES	EVI Solenoid Valve
V_EB	EVI Bypass Valve

Classification	Description
V_HG	Hot Gas Bypass Valve
V_4W	4way Valve
V_AR	Accumulator Oil Return Valve
CV_E	EEV Bypass Check Valve
CV_D	Discharge Check Valve
T_D	Discharge Temperature Sensor
T_S	Suction Temperature Sensor
T_CO	Condenser Out Temperature Sensor
T_EI	EVI In Temperature Sensor
T_EO	EVI Out Temperature Sensor
T_L	Liquid Tube Temperature Sensor
T_CT	Compressor Top Temperature Sensor
T_A	Ambient Temperature Sensor
SV_LG	Low Pressure Gas Pipe Service Valve
SV_L	Liquid Pipe Service Valve
SV_HG	High Pressure Gas Pipe Service Valve

Dimensional Drawings

Figure 16. Dimensional drawing: 4TVH/R0072****

Units: inches (mm)

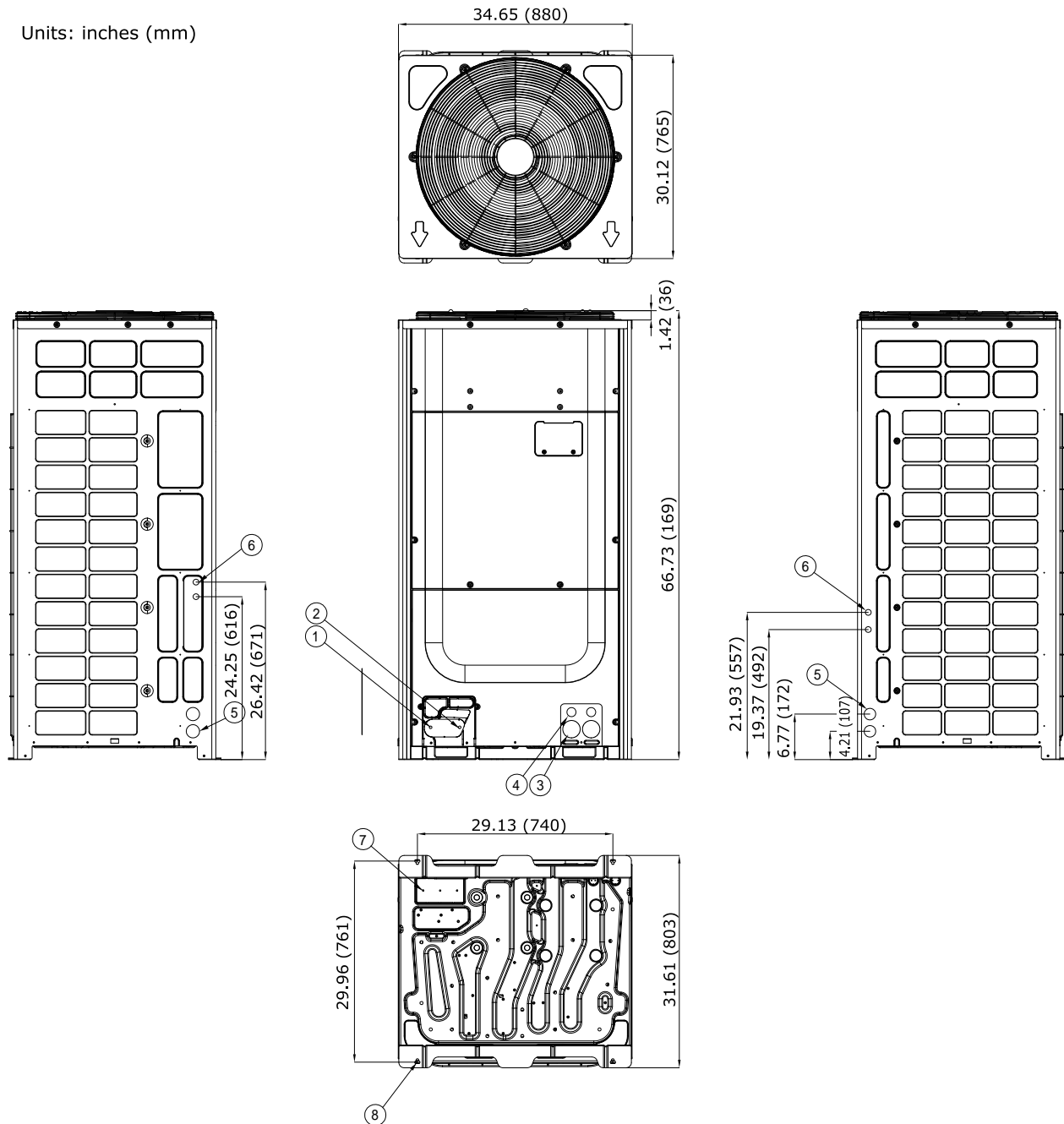

No.	Name	Description	No.	Name	Description
1	Gas refrigerant pipe	—	4	Communication wiring conduit	0.08 (2) - Ø1.36 (34.5)
2	Liquid refrigerant pipe	—	6		0.31 (8) - Ø0.87 (22.0)
3	Power wiring conduit	0.08 (2) - Ø1.72 (43.7)	7	Knock-out hole for refrigerant piping	178 x 76 (7 x 3)
5		0.16 (4) - Ø1.72 (43.7)	8	Anchor bolt hole	0.16 (4) - Ø0.47 (12)

Figure 17. Dimensional drawing: 4TVH/R0072** with discharge air ducts and wind/snow baffles**

Units: inches (mm)

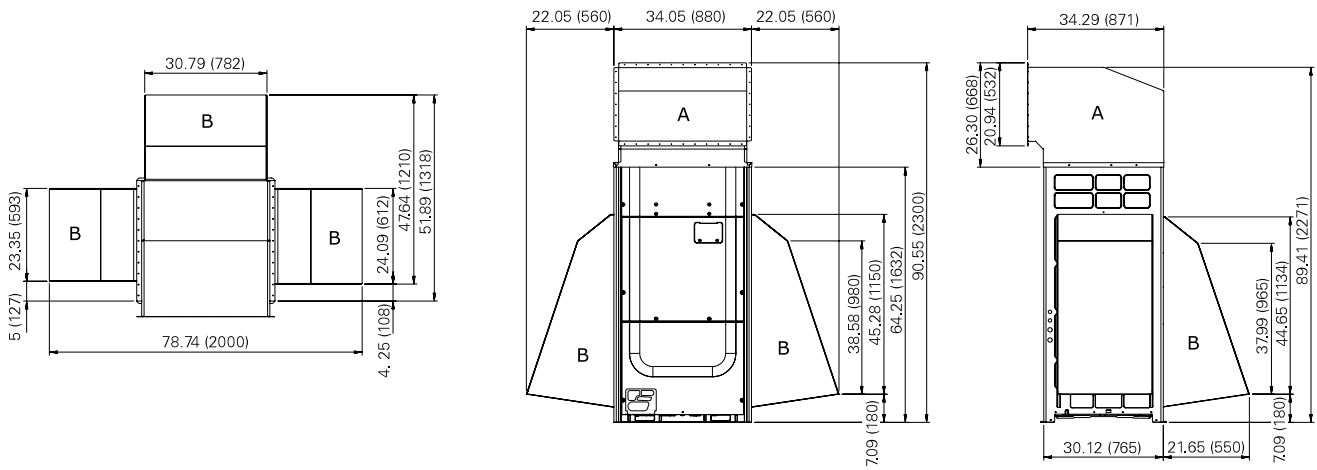

- A: Optional condenser air discharge duct and/or snow hood
- B: Optional wind/snow baffle

Figure 18. Dimensional drawing: 4TVH/R0096/120/144/168/192****

Units: inches (mm)

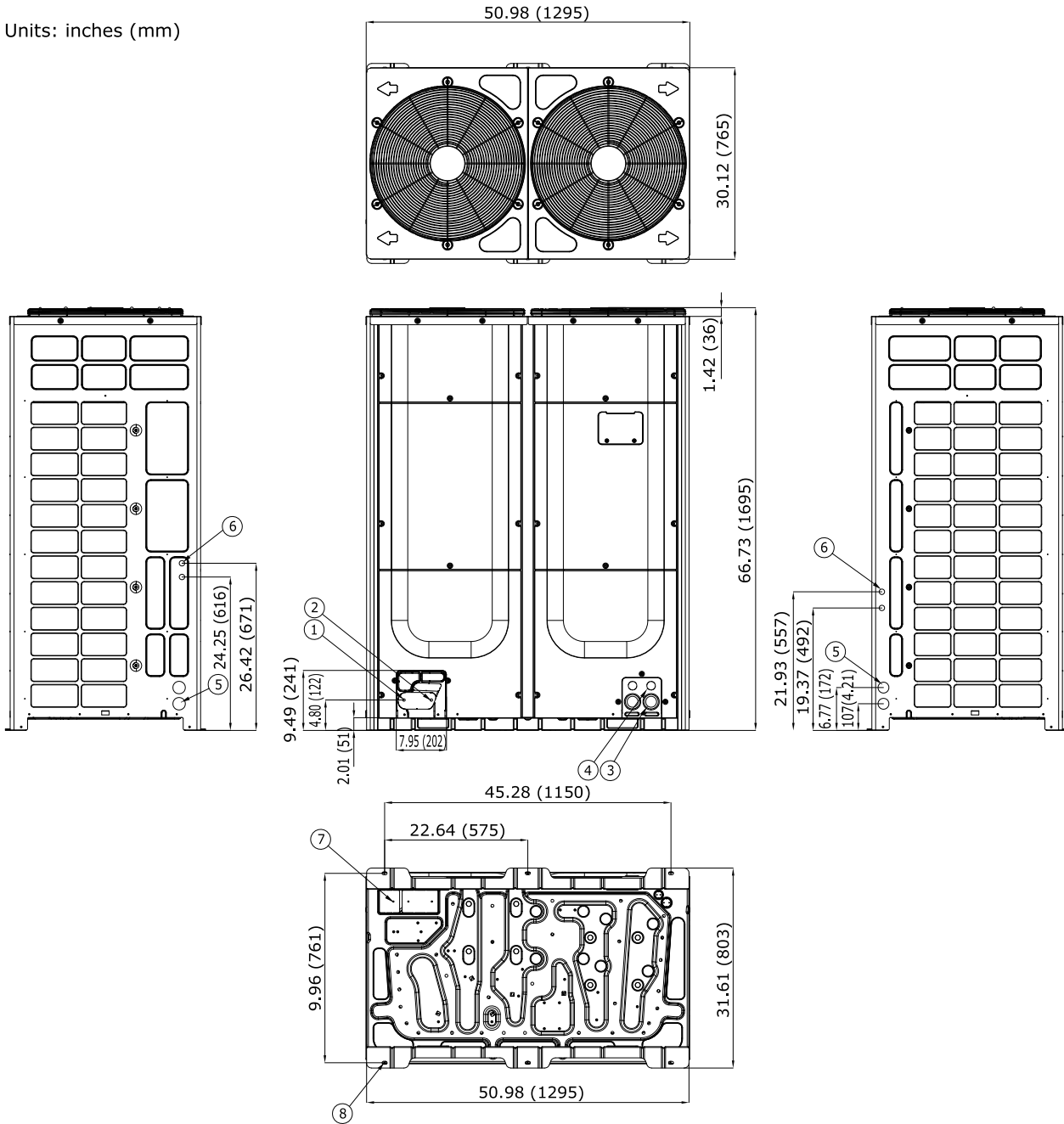

No.	Name	Description	No.	Name	Description
1	Gas refrigerant pipe	—	4	Communication wiring conduit	0.08 (2) - Ø1.36 (34.5)
2	Liquid refrigerant pipe	—	6		0.31 (8) - Ø 0.87 (22)
3	Power wiring conduit	0.08 (2) - Ø1.72 (43.7)	7	Knock-out hole for refrigerant piping	7 x 3 (178 x 76)
5		0.16 (4) - Ø1.72 (43.7)	8	Anchor bolt hole	0.16 (4) - Ø90.47 (12)

Figure 19. Dimensional drawing: 4TVH/R0096/120/144/168/192** with discharge air ducts and wind/snow baffles**

Units: inches (mm)

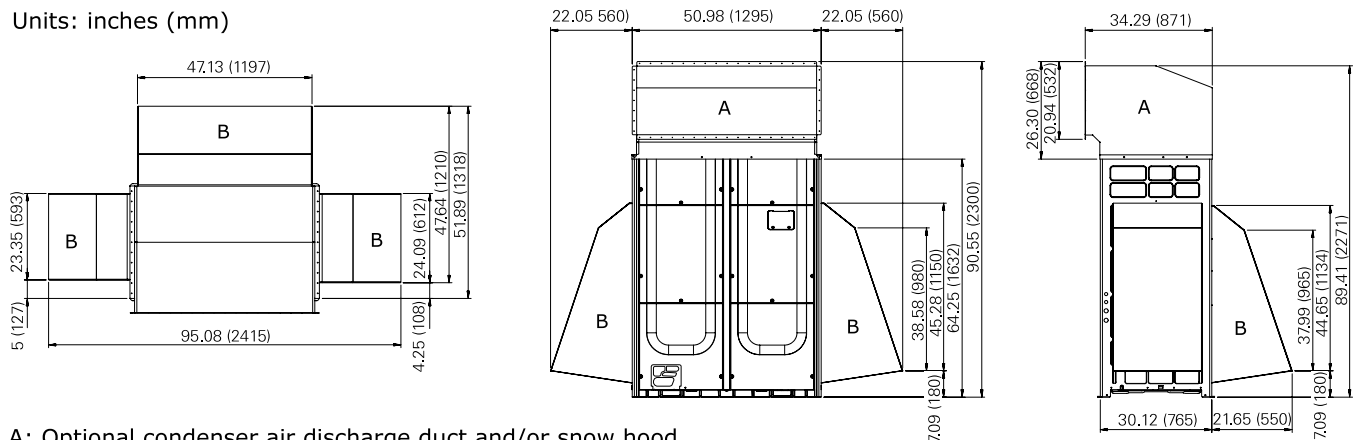

A: Optional condenser air discharge duct and/or snow hood
 B: Optional wind/snow baffle

Wind/Snow Baffle Installation (optional)

A wind/snow baffle should be installed:

- To prevent snow from accumulating on the outdoor unit and the risk of accumulated frost, which may interfere with normal heating operation.
- To protect the unit from humid air, such as near a sea shore.
- For heat recovery applications requiring the use of low ambient cooling (below 23°F [-5°C]).
- For applications requiring the use of low ambient heating (below 23°F [-5°C]).

Install the baffle so that:

- The discharge air and prevailing wind are not going the same direction.
- The discharge air is not directed to the enclosed area.
- The height (**h**) of the frame or base should be a minimum of 12 inches plus the additional height of the heaviest expected snowfall. (Example: If the base height is the minimum 12 inches and the heaviest expected snow load is 6 inches, then **h** = 12 inches + 6 inches = 18 inches).

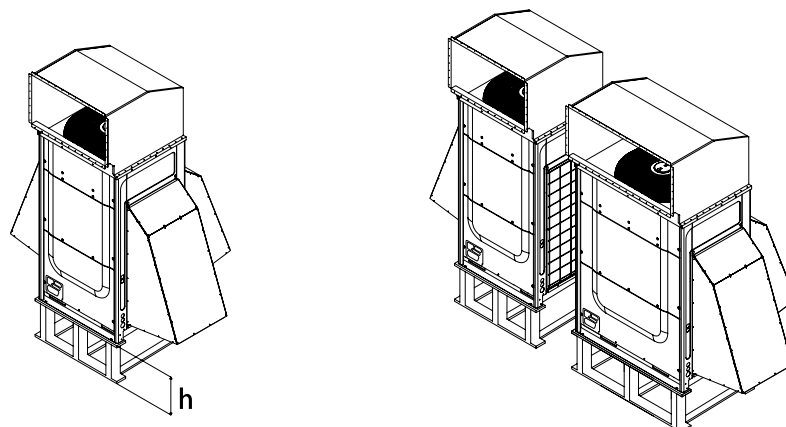



Trane optimizes the performance of homes and buildings around the world. A business of Ingersoll Rand, the leader in creating and sustaining safe, comfortable and energy efficient environments, Trane offers a broad portfolio of advanced controls and HVAC systems, comprehensive building services, and parts. For more information, visit www.Trane.com.

Trane has a policy of continuous product and product data improvements and reserves the right to change design and specifications without notice.

©2016 Trane All rights reserved

VRF-PRC008C-EN 15 Jan 2016

Supersedes VRF-PRC008B-EN (February 2015)

We are committed to using environmentally conscious print practices that reduce waste.

